

# TITLE VII: 2021 LAKE CARROLL BUILDING RULES AND REGULATIONS

<u>Chapter</u>	<u>Page</u>
<b>CHAPTER 70: GENERAL PROVISIONS.....</b>	<b>4</b>
<b>CHAPTER 71: LAKE CARROLL CONSTRUCTION PERMIT/PLAN REQUIREMENTS .....</b>	<b>9</b>
<b>CHAPTER 72: LAKE CARROLL BUILDING RULES AND REGULATIONS.....</b>	<b>21</b>
<b>CHAPTER 73: OTHER ARCHITECTURAL AND ENVIRONMENTAL CONTROLLED ISSUES.....</b>	<b>45</b>
<b>CHAPTER 74: A&amp;E COMMITTEE POLICIES.....</b>	<b>51</b>
<b>APPENDIX A: LAKE CARROLL ASSOCIATION COVENANTS AND RESTRICTIONS SECTIONS 1, 2, 3, 4, 5, 12, 13, 16, 17, 18, 20, 30 .....</b>	<b>55</b>
<b>APPENDIX B: LAKE CARROLL ASSOCIATION COVENANTS AND RESTRICTIONS SECTIONS 15, 19, 21, 22, 23, 24, 25, 26, 27, 28, 29, 31.....</b>	<b>55</b>
<b>APPENDIX C: LAKE ACCESS LOTS; RANCHETTE AND EQUESTRIAN LOTS.....</b>	<b>56</b>
<b>APPENDIX D: LAKE CARROLL ASSOCIATION FORMS .....</b>	<b>59</b>
<b>AMENDMENTS .....</b>	<b>60</b>

*When viewing electronically, click topic link above to jump to that chapter.*

## TABLE OF CONTENTS

*When viewing electronically, click on topic below to be directed to that section.*

<b>CHAPTER 70: GENERAL PROVISIONS.....</b>	<b>4</b>
GENERAL PROVISIONS .....	4
§ 70.01 BUILDING AT LAKE CARROLL.....	4
§ 70.02 ADOPTION OF INTERNATIONAL AND STATE CODES.....	4
FINES, FEES AND PENALTIES.....	4
§ 70.15 FINE STRUCTURE POLICY.....	4
§ 70.16 FEES AND PENALTIES.....	5
<b>CHAPTER 71: LAKE CARROLL CONSTRUCTION PERMIT/PLAN REQUIREMENTS .....</b>	<b>9</b>
GENERAL PROVISIONS.....	10
§ 71.01 MINIMUMS.....	10
CONSTRUCTION PERMIT/PLAN REQUIREMENTS .....	10
§ 71.15 REVIEW.....	10
§ 71.16 MINIMUM BUILDING PLAN REQUIREMENTS.....	11
§ 71.17 MINIMUM GRADING PLAN REQUIREMENTS.....	12
§ 71.18 BUILDING ELEVATIONS.....	12
§ 71.19 TYPICAL SECTION.....	13
§ 71.20 FLOOR PLANS.....	13
§ 71.21 WHIRLPOOLS, HOT TUBS AND SPAS.....	13
§ 71.22 ROOF OR FLOOR TRUSSES.....	13
§ 71.23 DRIVEWAY.....	13
§ 71.24 PRE-DRAWN DRAWINGS.....	13
§ 71.25 CROSS SECTIONS.....	14
§ 71.26 BASIC MECHANICAL REQUIREMENTS.....	14
§ 71.27 BASIC ELECTRICAL REQUIREMENTS.....	14
§ 71.28 PLUMBING.....	15
§ 71.29 SEPTIC/WELL/SOILS REPORT .....	16
§ 71.30 FIREPLACES.....	16
§ 71.31 GUARDRAILS/HANDRAILS.....	17

Lake Carroll Association, IL Code of Ordinances

§ 71.32	DETACHED GARAGE/SHED/GAZEBO.....	17
§ 71.33	PORCHES AND DECKS.....	17
	FOOTING/FOUNDATION PLAN.....	17
§ 71.45	FOOTING SIZES (MINIMUM).....	17
§ 71.46	FOUNDATION THICKNESS (MINIMUM).....	18
	FLOOR PLANS.....	18
§ 71.60	GARAGE.....	18
§ 71.61	ROUGH FRAMING.....	18
§ 71.62	CRAWL SPACE.....	19
§ 71.63	BASEMENT.....	19
§ 71.64	FLOOR SLABS ON GRADE (HABITABLE ROOMS ONLY).....	20
§ 71.65	HABITABLE FLOORS.....	20
§ 71.66	TEAR-DOWN GUIDELINES.....	20
<b>CHAPTER 72:</b>	<b>LAKE CARROLL BUILDING RULES AND REGULATIONS.....</b>	<b>21</b>
	GENERAL PROVISIONS.....	22
§ 72.01	BUILDING APPROVAL.....	22
§ 72.02	COLORS AND MATERIALS.....	22
§ 72.03	LP TANKS.....	23
§ 72.04	ADJACENT PROPERTY.....	23
§ 72.05	PLATTING/REPLATTING OF LOTS.....	23
	SPECIFIC REGULATIONS.....	26
§ 72.15	CAMPGROUND.....	26
§ 72.16	LOT PLOT PLANS.....	26
§ 72.17	FOR PERMIT ISSUANCE AND COMPLETION OF CONSTRUCTION.....	27
§ 72.18	PRIVATE SEWAGE DISPOSAL SYSTEM.....	27
§ 72.19	SEWAGE DISPOSAL REGULATIONS.....	28
§ 72.20	LAKE CARROLL SEPTIC INSPECTION/PUMPING SCHEDULE.....	28
§ 72.21	CULVERT REQUIREMENTS AND DRIVEWAYS.....	29
§ 72.22	MANDATORY INSPECTIONS.....	29
§ 72.23	MISCELLANEOUS BUILDING REQUIREMENTS.....	29
§ 72.24	EROSION CONTROL.....	29
§ 72.25	MODULAR HOMES.....	30
§ 72.26	PLUMBING.....	30
§ 72.27	ELECTRICAL REQUIREMENTS.....	30
§ 72.28	SHORELINE STABILIZATION POLICY.....	30
§ 72.29	RESIDENTIAL PIERS, DOCKS AND SWIM PLATFORMS.....	33
§ 72.29.1	LAKE STRUCTURES, DEBRIS, AND BUOYS.....	34
	ACCESSORY BUILDINGS (INCLUDING, BUT NOT LIMITED TO SHEDS, BEACH HOUSES, GARAGES, BARNs, STABLES & LOAFING SHEDS).....	34
§ 72.30	SHEDS.....	34
§ 72.31	GAZEBOS/PERGOLAS/PAVILIONS.....	35
§ 72.32	BARNs, STABLES & LOAFING SHEDS.....	35
§ 72.33	BEACH HOUSES.....	36
§ 72.34	DETACHED GARAGES.....	37
§ 72.35	ATTACHED DECKS.....	37
§ 72.36	FENCES.....	38
§ 72.37	OCCUPANCY PERMIT.....	38
§ 72.38	ANTENNA, TOWERS, AND FLAGPOLES.....	38
§ 72.39	SATELLITE DISH.....	39
§ 72.40	COMMERCIAL BUILDING REQUIREMENTS AND SPECIFICATIONS.....	39
§ 72.41	PRIVATE SWIMMING POOLS, HOT TUBS AND SPAS.....	39
§ 72.42	LANDSCAPING.....	40
§ 72.43	WELLS.....	41
§ 72.44	LP PROPANE TANKS.....	41
§ 72.45	FUEL STORAGE.....	42

Lake Carroll Association, IL Code of Ordinances

§ 72.46 PV SOLAR PANELS .....42  
§ 72.47 TEMPORARY STRUCTURES .....42  
VARIANCE POLICY .....42  
§ 72.55 VARIANCES GENERALLY .....42  
§ 72.56 SETTING HEARING OR MEETING; TIME LIMITATION. ....43  
§ 72.57 NOTICES. ....43  
§ 72.58 VARIANCE CRITERIA. ....44

**CHAPTER 73: OTHER ARCHITECTURAL AND ENVIRONMENTAL CONTROLLED ISSUES.....45**  
SIGN POLICY .....45  
§ 73.01 NON-COMMERCIAL SIGNS. ....45  
§ 73.02 COMMERCIAL SIGNS.....46  
§ 73.03 POLITICAL CAMPAIGN SIGNS. ....50

**CHAPTER 74: A&E COMMITTEE POLICIES.....51**  
§ 74.01 VIOLATION. ....51  
§ 74.02 RETAINING WALLS, WATERFRONT DECKS, PIERS, ETC.....51  
§ 74.03 DRIVEWAYS AND CULVERTS. ....51  
§ 74.04 ADJACENT PROPERTY. ....51  
§ 74.05 CONSTRUCTION HOURS AND DEBRIS REMOVAL.....52  
§ 74.06 MAINTENANCE OF LOTS. ....52  
§ 74.07 APPLYING OF FERTILIZERS IN LAKE CARROLL.....52  
§ 74.08 MOWING POLICY.....53  
§ 74.09 NUISANCE ANIMAL CONTROL POLICY. ....54

**APPENDIX A: LAKE CARROLL ASSOCIATION COVENANTS AND RESTRICTIONS SECTIONS  
1, 2, 3, 4, 5, 12, 13, 16, 17, 18, 20, 30 .....55**

**APPENDIX B: LAKE CARROLL ASSOCIATION COVENANTS AND RESTRICTIONS SECTIONS  
15, 19, 21, 22, 23, 24, 25, 26, 27, 28, 29, 31.....55**

**APPENDIX C: LAKE ACCESS LOTS; RANCHETTE AND EQUESTRIAN LOTS.....56**  
LAKE ACCESS LOTS .....56  
RANCHETTE and EQUESTRIAN LOTS .....57

**APPENDIX D: LAKE CARROLL ASSOCIATION FORMS.....59**

**AMENDMENTS.....60**

## **CHAPTER 70: GENERAL PROVISIONS**

Section

### ***General Provisions***

- 70.01 Building at Lake Carroll
- 70.02 Adoption of International and State Codes

### ***Fines, Fees and Penalties***

- 70.15 Fine structure policy
- 70.16 Fees and penalties

## **GENERAL PROVISIONS**

### **§ 70.01 BUILDING AT LAKE CARROLL.**

(A) (Any violations within this section will result in fines as outlined in Fine Structure - See §§ 70.15 and 70.16.)

(B) If you are planning to build, there are several steps to follow in order to ensure a smooth evaluation of your plans.

(A&E Intro)

### **§ 70.02 ADOPTION OF INTERNATIONAL AND STATE CODES.**

The Lake Carroll Property Owners Association has adopted the following International and State Codes as of January 1, 2019.

- (A) 2015 International Building Code.
- (B) IL Energy Conservation Code. (Current Edition)
- (C) IL Plumbing Code. (Current Edition)
- (D) 2015 International Residential Code.
- (E) NEC (Electrical Code). (Current Edition)
- (F) IL Accessibility Code. (Current Edition)

(A&E Intro) (Major changes BOD Approved 10-18-2013; Effective 1-1-2014; Major changes BOD Approved 10-24-2014; Effective 1-1-2015)

## **FINES, FEES AND PENALTIES**

### **§ 70.15 FINE STRUCTURE POLICY.**

All LCA Property Owners are responsible for their actions and the actions of their Contractors & Sub-Contractors while performing work on their property. Any and all fines will be assessed to the Property Owner per the following:

(1) Any Owner performing any work without first obtaining permits as required by the A&E Rules and Regulations.

(2) Any Owner allowing a non-registered contractor to perform work within Lake Carroll requiring a permit and contractor registration.

(3) Any Owner, or the Owner's contractor/subcontractor performing work not in accordance with the current A&E Rules and Regulations in effect as of January 1, 2013, and all subsequent amendments.

(4) Any Owner failing to apply for a variance as required.

(5) Any Owner, or their contractor/subcontractor, failing to comply with the direction of the Lake Carroll Building Inspector or the decisions of the A&E Committee.

(6) Any Owner, or their contractor/subcontractor, engaging in any misrepresentation or fraud in connection with a permit application, the materials to be used, the contractor(s)/subcontractor(s) performing actual work, etc.

(7) Installation of any improvement without first obtaining permit will cost up to \$2,500, permit *fee will be doubled* plus *\$25/day* until permit is granted.

(8) Variances granted *after* installation of improvement will cost up to \$2,500, plus *\$50/day until variance is granted*.

(9) Failure of Owner or their contractor/subcontractor to obtain any required inspection (24-hour notice required) will cost *\$250* plus *\$25/day* until inspection is requested.

(10) Failure of the Owner to obtain occupancy permit prior to moving anything into a newly constructed home is cause for both the homeowner and the general contractor each receiving a \$250 fine and \$25 per day until permit is obtained from the Building Inspector.

(11) When violations are detected by the Building Inspector fines may be assessed. All rules and regulations are stated in the current A&E Building Rules and Regulations.

(12) All violations will be addressed and fines or "Stop Work Orders" may be issued immediately.

(13) Fines are to be paid immediately and corrections may be required by the Building Inspector, or an order to *stop work immediately* will be issued.

(14) If material or prints are changed, updated information from the homeowner is needed for the A&E Committee to approve the changes.

(15) Failure of the Owner to obtain permit for the original installation of any pier, dock, boat lift and/or electric "Aqua Thruster" type system. will cost *\$100*.

(16) Failure to apply both reflective material and section/lot numbers to any pier, dock and/or boat lift.

(17) ANY AND ALL FINES/DECISIONS CAN BE APPEALED TO THE LCA BOD.

In all cases, the Building Inspector has the authority to place a *stop work order* on a job until all fines are paid, violations are corrected, or the A&E Committee has granted a variance. (A&E, Policy) (Major changes BOD Approved 11-18-2011; Effective 1-1-2013; Major changes BOD Approved 10-18-2013; Effective 1-1-2014) Violation of the LCA A&E Building Rules & Regulations will result in the Property Owner of record being charged according to the following fine structure:

## **§ 70.16 FEES AND PENALTIES.**

A&E Fees & Penalties Addendum # 2008-01 (Board Approved 12-22-2008)

Lake Carroll Association, IL Code of Ordinances

Permit Fees		Permit Valid	Extensions	
		1		2-3
New Home *	Sq Footage	1 year not to exceed 20 months total	6 Mo. \$250	\$150/Mo.
Addition	Sq Footage	1 year not to exceed 20 months total	6 Mo. \$250	\$150/Mo.
Accessory Building	sf x 27 x .0025	6 Mo.	3 Mo \$50	
Barns and Stables	sf x 27 x .0025	6 Mo.	3 Mo \$100	
Beach House	sf x 27 x .0025	6 Mo.	3 Mo \$100	
Decks	\$25	6 Mo.	3 Mo \$50	
Driveway	\$25	6 Mo.	3 Mo/\$25	
External Wood burner/alternate fuel	\$25	6 Mo	3 Mo/\$50	
Fences	\$25	6 Mo.	3 Mo/\$50	
Garage (Detached)	sf x 27 x .0025	6 Mo.	3 Mo/\$100	
Gazebo	\$25	6 Mo.	3 Mo/\$50	
In-ground Swimming Pool	\$50	6 Mo.	3 Mo/\$100	
Landscaping	\$25	Not to exceed 1 yr.	3 Mo/\$50	
Lot Clearing	\$25	6 Mo.	3 Mo/\$50	
Riprap	None			
Satellite Dish (greater than 36")	\$25	6 Mo.	3 Mo/\$50	
Shed	\$25	6 Mo.	3 Mo/\$50	
Swimming Pools	\$25	6 Mo.	3 Mo/\$50	
Towers (no wind towers)	\$25	6 Mo.	3 Mo/\$50	
Greenway Pier or Dock	\$25			

\* Hardships to be considered on an individual basis by the A&E Committee

(Major changes BOD Approved 11-18-2011; Effective 1-1-2013)

Penalties	Fee	1st Fine	Minimum Fine Per Day	2nd Offense	3rd Offense
Installation without Permit	Doubled	Up to \$2,500	\$25		
Variance Hearing	\$250				

Lake Carroll Association, IL Code of Ordinances

Penalties	Fee	1st Fine	Minimum Fine Per Day	2nd Offense	3rd Offense
If Variance granted after improvement		Up to \$2,500	\$50		
Fail to get any required Inspection		\$250	\$25		
Fail to get Occupancy Permit prior to moving in		\$250	\$25		
Fail to get permit for Greenway Dock or pier		\$100			
Fail to apply reflective material and/or section/lot numbers on Piers, Docks or Boatlifts		\$50	\$10		
<b>Addendum # 2009-01 (Board Approved 11-20-2009)</b>					
Improved lot not mowed less than 6 in.		\$100			
Violation of any "Private Swimming Pool" construction rules			\$250 - \$500		
Construction Debris in ditches		\$250	Plus \$25		
Contractors signs left more than 7 days after final inspection			\$25		
Using adjacent property without permission on file		\$250	Plus \$25; plus stop work order		
All violations may be assessed		Up to \$2,500		Up to \$5,000	Loss of privilege to Build in Lake Carroll
<b>Contractor performing work requiring a permit not registered as a contractor with the Lake Carroll Property Owner's Association</b>		<b>Double registration fee</b>	<b>Or loss of contractor registration for up to 12 months</b>		

Lake Carroll Association, IL Code of Ordinances

<b>Penalties</b>	<b>Fee</b>	<b>1st Fine</b>	<b>Minimum Fine Per Day</b>	<b>2nd Offense</b>	<b>3rd Offense</b>
<b>Members will be given a written notice of any violation. They will be given 14 days from date of notice to cure violation before fines will be imposed. However, the Association reserves the right to issue a Stop Work Order and/or impose fines immediately.</b>					

(A&E, Fees and Penalties) (BOD approved 12-22-2008; Major changes BOD Approved 11-18-2011; Effective 1-1-2013)



**CHAPTER 71: LAKE CARROLL CONSTRUCTION**  
**PERMIT/PLAN REQUIREMENTS**

Section

*General Provisions*

71.01 Minimums

*Construction Permit/Plan Requirements*

- 71.15 Review
- 71.16 Minimum Building Plan Requirements
- 71.17 Minimum Grading Plan Requirements
- 71.18 Building Elevations
- 71.19 Typical Section
- 71.20 Floor Plans
- 71.21 Whirlpools, Hot Tubs and Spas
- 71.22 Roof or Floor Trusses
- 71.23 Driveway
- 71.24 Pre-Drawn Drawings
- 71.25 Cross Sections
- 71.26 Basic Mechanical Requirements
- 71.27 Basic Electrical Requirements
- 71.28 Plumbing
- 71.29 Septic/Well/PERC Test
- 71.30 Fireplaces
- 71.31 Guardrails/Handrails
- 71.32 Detached Garage/Shed/Gazebo
- 71.33 Porches and Decks

*Footing/Foundation Plan*

- 71.45 Footing Sizes (Minimum)
- 71.46 Foundation Thickness (Minimum)

*Floor Plans*

- 71.60 Garage
- 71.61 Rough Framing
- 71.62 Crawl Space
- 71.63 Basement
- 71.64 Floor Slabs on Grade (Habitable Rooms Only)
- 71.65 Habitable Floors
- 71.66 Tear-Down Guidelines

## GENERAL PROVISIONS

### § 71.01 MINIMUMS.

**THE FOLLOWING REQUIREMENTS ARE TO BE CONSIDERED AS MINIMUMS. THEY DO NOT COVER ALL CONCEIVABLE DRAWINGS, CODES OR CONDITIONS FOR SPECIFIC ITEMS.**

**CALL BEFORE YOU DIG**

**CONTACT J.U.L.I.E. @ 1-800-892-0123 FOR UNDERGROUND UTILITY LOCATIONS.**

**PROVIDE THE ISSUED DIG NUMBER TO THE BUILDING INSPECTOR.**

(A&E, Ch. I) (Major change BOD Approved 10-24-2014; Effective 1-1-2015)

## CONSTRUCTION PERMIT/PLAN REQUIREMENTS

### § 71.15 REVIEW.

(A) (1) Only Members in good standing may receive a building permit.  
(2) Applications must be submitted and fully completed with all information and fees as requested. All contractors and subcontractors must be registered with the Lake Carroll Association and submit proof of insurance with Lake Carroll Association as certificate holders. You may register at the Association office. This must be done PRIOR to the start of any construction project at Lake Carroll.

(3) Only complete applications will be reviewed by the A&E Committee. Incomplete applications and plans will be tabled until all information is received and then reviewed at the next regularly scheduled A&E Committee meeting. All plans must also include, on all pages, owner's name and Section and Lot of construction to be considered complete.

(B) (1) Building permit fee for dwelling. (Reference "Building Permit" fee pages - See § 70.16)

(2) Escrow for damage/completion deposit \$1,000 (Check must be contractor's check.)

(3) For residential or commercial construction, a \$1,955 impact fee.

(4) Include name of contractor and list of all current subcontractors. The Building Inspector needs to be notified of the subcontractor changes prior to their work being done on project.

(C) (1) Plans must be submitted by 2 pm on the Friday prior to next scheduled A&E Committee Meeting. Please check with Association office for any last-minute changes.

(2) When plans are approved by the A&E Committee, a letter will be sent stating work may begin. The A&E Committee will forward copies of the letter of approval to the utility companies and the Carroll County Zoning Officer and Assessors Office.

(3) New home plans must be submitted by 2pm on the Friday, 2 weeks prior to the next scheduled A&E Committee meeting. Please check the Association Office for any last-minute changes.

(D) New home or building projects may begin as soon as the A&E Committee has approved the project and the Lake Carroll Building Inspector has inspected the site to ensure the lot has been staked out according to the approved plans. If you have any questions, please contact the Lake Carroll Association office (815) 493-2552  
(A&E, Ch. I) (Major change BOD Approved 10-24-2014; Effective 1-1-2015)

## § 71.16 MINIMUM BUILDING PLAN REQUIREMENTS.

(A) The following are the minimum plan requirements for anyone planning to build a house, addition, garage, deck, pier, dock, accessory building, satellite dish, swimming pool, sign, rip rap, seawall or any other type of construction or site improvement. The requirements listed below will be used as a minimum guideline by the Committee when reviewing plans for compliance. The Committee may reject applications for non-conformance to any of the items required. Plans must be submitted to the LC Architectural and Environmental (A&E) Committee and must conform to LCA adopted codes, LCA Building Requirements outlined in the Associations Covenants & Restrictions and Building Rules and Regulations and must be stamped by a registered professional stating that the plans conform to the current codes adopted by the Association. Pursuant to the 2015 IRC, Section 106, R106.1 Construction Documents, paragraph “Exception”, the Committee has the authority to waive the professional stamp on a case by case basis. The types of construction documents that may not require a professional design stamp are listed below, but not limited to the following:

- (1) The work submitted does not have any or very limited structural, mechanical, electrical, or plumbing scope of work.
- (2) Interior Build-out (excluding structural revisions), Gazebos, Decks and cosmetic work.
- (3) Landscaping design (except retaining walls over 24 inches in height).
- (4) The plans must be submitted in legible format and contain all information as required by the LC building rules and regulations.
- (5) The plans submitted will be reviewed by the A&E Committee and must comply with all codes and life safety issues.

- (B) (1) Complete all permit applications, documents and submit with required fees.
- (2) Submit plans in triplicate on 24 inches x 36 inches format (minimum) for Homes, Additions, Garages, Beach Houses, Barns & Stables.
- (a) Submit PDFs for structures with condition space.
- (3) Submit proper RES/Check Energy Compliance Certificate for all new homes and additions.
- (4) Submit IDPH documents/approval for well and septic systems.
  - (5) Submit soils scientist report.

(C) **Prior to making any additions, deletions, or alternations from the approved plans you must notify the Building Inspector immediately. Any structural changes will require a revised drawing and approval by the A&E Committee. If you relocate or add any structure you may be required to resubmit a new survey.**

(A&E, Ch. I) (Major change BOD Approved 10-24-2014; Effective 1-1-2015)

**§ 71.17 MINIMUM GRADING PLAN REQUIREMENTS.**

- (A) Provide an accurate survey that must reflect the existing improvements including proposed construction and/or changes that the permit is being requested for.
  - (B) Plan must be prepared by an Illinois Registered Professional Engineer or an Illinois Registered Land Surveyor.
  - (C) Delineation/location of all existing and proposed easements, such as utilities, drainage.
  - (D) Benchmark and proposed grades.
  - (E) Existing and proposed topography at one (1) foot contour intervals and any necessary/critical spot elevations.
  - (F) Drainage arrows along lot lines and wherever else appropriate.
  - (G) Finished grades at least one-half (0.5) feet below top of foundation, directing slope away from the foundation.
  - (H) Provide the proposed top of foundation elevation (and the lowest opening elevation). For lakefront construction, the lowest floor level of all homes must be at least six (6) feet above the 740-pool level.
  - (I) Provide the top and bottom elevations of any proposed retaining wall, along with a cross-section detail for the proposed design. Manufacturer's specification sheets will need to be provided on those wall sections that are pre-made (e.g. interlocking wall system). Retaining walls 24 inches or more in height require the certification of An Illinois Registered Structural Engineer
  - (J) Sediment protection (such as silt fencing) must be properly installed. Other acceptable and practical methods may be used.
  - (K) Provide the location and design detail of the construction entrance and any culvert sedimentation protection.
  - (L) Indicate Well and Septic Locations.
  - (M) Indicate LP tank location if applicable.
  - (N) Before framing can start on a new house, the foundation must be located, and a plat prepared by an Illinois Professional Land Surveyor showing the dimensions to the property lines. This may be done after forms are set and before concrete is poured.
  - (O) All set back lines and easements are to be indicated and followed. See "Setbacks" in Appendices A, B & C.
  - (P) If required to meet the 40% limitation set out in Appendix A, paragraph III or Appendix B, paragraph III, provide the following information on the site plan or grading plan: Area of lot, combined area of existing impervious improvements, area of proposed impervious improvements and calculation showing total of current and proposed impervious improvements meet the requirements of the above referenced Appendix A and Appendix B paragraphs (all areas to be shown in square feet)
- (A&E, Ch. I) (Major change BOD Approved 10-24-2014; Effective 1-1-2015)

**§ 71.18 BUILDING ELEVATIONS.**

- (A) Indicate a complete, roof to/and including foundations. Front, rear and side views of the proposed structure. If it is a room addition or attached garage, a portion of the existing

structure at the portion of attachment must be shown. Label each elevation. Indicate exterior material type and color to be used.

(B) For lakefront construction, the lowest floor level of all homes must be at least six (6) feet above the 740-pool level.  
(A&E, Ch. I) (Major change BOD Approved 10-24-2014; Effective 1-1-2015)

#### **§ 71.19 TYPICAL SECTION.**

A cutaway view through a frame wall and/or brick veneer wall showing footing, foundation, floor, wall, ceiling, and roof construction. Each structural component must be labeled as to size and type of material. Drawings cannot be reviewed without this information.  
(A&E, Ch. I) (Major change BOD Approved 10-24-2014; Effective 1-1-2015)

#### **§ 71.20 FLOOR PLANS.**

These must show the locations of any doors or windows, electrical openings, plumbing fixtures, direction and size of floor and ceiling joists. Rooms should be labeled as to their use and whether or not they are new or existing. Second story additions must show what is on the first floor to support the addition. All plans to be fully dimensioned to scale.  
(A&E, Ch. I) (Major change BOD Approved 10-24-2014; Effective 1-1-2015)

#### **§ 71.21 WHIRLPOOLS, HOT TUBS AND SPAS.**

Must submit specifications and must have U.L. label or equivalent. Location of access to motor must be indicated on plans.  
(A&E, Ch. I) (Major change BOD Approved 10-24-2014; Effective 1-1-2015)

#### **§ 71.22 ROOF OR FLOOR TRUSSES.**

Submit structural specifications if prefab. If “home-built,” detailed drawings must be submitted. All truss plans and specifications must have an ILLINOIS Architect’s or ILLINOIS Structural Engineer’s seal. (Not required for “TJI” type prefab trusses.)  
(A&E, Ch. I) (Major change BOD Approved 10-24-2014; Effective 1-1-2015)

#### **§ 71.23 DRIVEWAY.**

Location must be shown on site plan with dimensions from property line.  
(A&E, Ch. I) (Major change BOD Approved 10-24-2014; Effective 1-1-2015)

#### **§ 71.24 PRE-DRAWN DRAWINGS.**

If obtained from mail order or from a plan service, must be revised to reflect alterations made by owner. For example, a poured concrete foundation is to be used instead of concrete block, this revision must be noted wherever the concrete block was shown. Please note some

mail order plans are very “generic” and will require professional adjustments to be approved. Any “optional or future” items must be deleted from plans.

(A&E, Ch. I) (Major change BOD Approved 10-24-2014; Effective 1-1-2015)

#### **§ 71.25 CROSS SECTIONS.**

- (A) Roof sheathing must be at least one-half (1/2) inch thick.
  - (B) Sub-flooring must be three-fourths (3/4) inch tongue and groove.
  - (C) Drain tile in 12 inches of stone cover as well as foundation damp-proofing is required on the outside of all crawl spaces and basements.
  - (D) If brick veneer is used, a separate cross section must be submitted.
  - (E) Attics and cathedral ceilings must meet the -Illinois Energy Code.
  - (F) Exterior walls must meet the Illinois Energy Code.
  - (G) Cathedral rafters must be deep enough to meet the -Illinois Energy Code.
  - (H) Minimum 30# felt (or equivalent material) must be used for all types of roofing.
- (A&E, Ch. I) (Major change BOD Approved 10-24-2014; Effective 1-1-2015)

#### **§ 71.26 BASIC MECHANICAL REQUIREMENTS.**

- (A) Illinois law requires that all heating systems comply with the Energy Code. It is the Owner’s responsibility to comply with this code.
  - (B) Heating and Cooling equipment shall be sized based on building loads calculated in accordance with approved heating and cooling methodologies.
  - (C) Heating and cooling equipment shall be installed in accordance with the manufacturer’s instructions and requirements. All equipment shall be coordinated with building construction and other equipment to provide for adequate clearances for servicing and replacement. Ceilings above furnaces must be covered with five-eighths (5/8) inch Type “X” drywall and joints fire taped.
  - (D) Combustion air shall be supplied for fuel fired furnaces.
  - (E) Electric baseboard convectors shall be installed in accordance with the manufacturer’s instructions and requirements.
  - (F) Condensate from cooling coils shall be conveyed from the unit to a floor drain within the mechanical room. No exterior discharge or drain pans are allowed.
  - (G) Fireplaces and metal flues must be installed per manufacturer’s specification and documentation must be submitted at time of inspection.
  - (H) Fueled fireplaces are restricted in sleeping rooms, bathrooms, storage closets.
  - (I) Clothes dryer vents shall be aluminum, properly sized, with taped joint (no screws) and not exceed 25 feet in length.
  - (J) Bathroom exhaust must be installed in every bathroom/toilet room and duct run to outside air.
- (A&E, Ch. I) (Major change BOD Approved 10-24-2014; Effective 1-1-2015)

#### **§ 71.27 BASIC ELECTRICAL REQUIREMENTS.**

- (A) All residential home electrical services shall be minimum 200 amp three (3)-wire. Service must be located in building to provide minimum of three (3) feet of clearance in front of

service for adequate servicing or replacement. Service feeder from meter to panel must be installed in EMT properly sized and a maximum of six (6) feet exposed. All services must be underground. NO overhead service mast allowed. Services must be grounded with proper sized copper grounding rod. The rod shall be driven to a depth of not less than eight (8) feet.

(B) All outlets in garage, in bathrooms, exterior, in crawl spaces and unfinished basements, in floors and within six (6) feet of any sink must be on GFI. GFI outlet required at each bathroom sink.

(C) Each room must have outlets spaced no farther than 12 feet apart. Each wall space 48 inches or wider must have an outlet.

(D) Every four (4) feet of kitchen counter space including island and peninsular countertops must have an outlet as well as counter 12 inches or wider. A minimum of one (1) outlet is required in islands, peninsular countertops, etc., and is to be maximum 12 inches below top. These outlets cannot be installed in "face-up" position in countertop. Kitchen countertop, island and peninsular outlets must be GFI protected and on a 20-amp circuit.

(E) Exhaust fan installed in a bathroom must be switched separately from any lights.

(F) Each room must have either one (1) switched overhead light or one switched outlet. If a room has more than one (1) entrance it must have a switch at each entrance all tied to the same light or receptacle.

(G) Tamper proof receptacles required.

(H) Every exterior door must have a switched outside light including sliding glass doors.

(I) At least one (1) weatherproof GFI outlet must be installed on the exterior front and rear of the house, in the garage and in each bathroom, near sink. Each bathroom sink requires its own GFI outlet.

(J) A 110-volt smoke detector is required on each floor level including basement, inside and outside of each bedroom and garages. All detectors must be wired in series and have battery backup.

(K) Carbon monoxide detectors shall be installed outside of each separate sleeping area. All detectors must be wired in series and have battery backup.

(L) All whirlpools, hot tubs and spas must be on a GFI circuit.

(M) No switches or outlets can be closer than five (5) feet to the edge of a tub or shower unless by GFCI breaker in panel.

(N) Any lights above bathtubs or showers or wet areas must be waterproof and on a GFI circuit.

(O) Any hallway ten (10) feet in length or longer requires one (1) outlet.

(P) All 20-amp circuits must have 20-amp receptacles.

(Q) Closet lights to be fluorescent or recessed can fixture.

(R) A switched light is to be provided at attic access.

(S) AFCI to be installed as required by NEC.

(A&E, Ch. I) (Major change BOD Approved 10-24-2014; Effective 1-1-2015)

## § 71.28 PLUMBING.

(A) Must comply with State of Illinois Plumbing Code.

(B) Where the laundry facilities occur on second floor, a pan with floor drain to sanitary is required under washer.

- (C) No unions, couplings, bushings, flared fittings shall be in concealed conditions.
  - (D) No copper tubing shall be used for either Natural or LP gas installations.
  - (E) Protect gas pipe from corrosion when passing through foundation walls or exposed locations.
- (A&E, Ch. I) (Major change BOD Approved 10-24-2014; Effective 1-1-2015)

### § 71.29 SEPTIC/WELL/SOILS REPORT

- (A) (1) Submit a Soils Report from a qualified soils scientist.
  - (2) Submit a septic system approved by the *Carroll County Department of Health*. The minimum size septic field must be for a four (4) bedroom home. A Variance might be obtained for a three (3) bedroom home providing the home qualifies and an agreement constituting a restriction on the property is signed and recorded at the Carroll County Recorder's Office to that effect.
  - (3) On new construction survey, locate the placement of the well and septic on the plot plan, and observe the required distance of separation (50 feet from the septic tank to the well, 75 feet from septic field or system to the well).
  - (4) The Illinois/Carroll County Department of Health must approve the septic system. See "Private Sewage Disposal System", § 72.18, for additional information.
  - (5) Septic tanks are required to be pumped periodically to prevent them from malfunctioning therefore the septic tank and well should be placed on the lot so they are *easily accessible to service*.
- (B) During 1992 Lake Carroll changed the method to determine lot suitability for a septic system from the standard percolation tests to soil borings. For 1995 and beyond the following is required.
- (1) The applicant for soil borings on the lot provide a sketch reflecting the size and shape of lot complete with dimensions.
  - (2) The sketch should show the approximate location of the home upon the lot.
  - (3) The lot needs to be clearly marked so the soil borings will be within the boundaries.
  - (4) Soil Scientist will meet the lot owner or contractor if possible.
  - (5) Soil Scientist will make soil borings where the lot owner would like to locate septic system. If the soils are not suitable for the conventional system, check the entire lot to select a suitable area if possible.
- (A&E, Ch. I) (Major change BOD Approved 10-24-2014; Effective 1-1-2015)

### § 71.30 FIREPLACES.

- (A) Must indicate if prefab or masonry.
- (B) If a prefab fireplace is going to be used, it must have an Underwriter's Laboratories label and include the manufacturer's installation procedures.
- (C) If the fireplace is to be constructed of masonry, a complete cross section through the fireplace must be submitted. The section must show the footing size (at least 12 inches thick), wall thickness (at least eight (8) inches of solid brick) and the flue size (size varies depending



upon the opening size of the fireplace). Indicate height and width dimensions of opening and depth of firebox along with hearth dimensions.

(A&E, Ch. I) (Major change BOD Approved 10-24-2014; Effective 1-1-2015)

### **§ 71.31 GUARDRAILS/HANDRAILS.**

All stairs over two (2) risers require 36-inch guardrails with balusters maximum four (4) inches apart. A handrail 34 inches to 38 inches is required on one (1) side. This may be incorporated into guardrail if proper grasp requirements are met.

(A&E, Ch. I) (Major change BOD Approved 10-24-2014; Effective 1-1-2015)

### **§ 71.32 DETACHED GARAGE/SHED/GAZEBO.**

(A) Submit dimensioned site plan showing existing setbacks, easements, structures, and drives.

(B) A cutaway view through a frame wall and/or brick veneer wall showing footing, foundation, floor, wall, ceiling and roof construction. Each structural component must be labeled as to size and type of material. Drawings cannot be reviewed without this information.

(C) Please Note: If you are not planning to build a garage immediately, the plot plan must include the possible location and size of a future garage for location perspective purposes.

(A&E, Ch. I) (Major change BOD Approved 10-24-2014; Effective 1-1-2015)

### **§ 71.33 PORCHES AND DECKS.**

(A) Requires size, direction and spacing of beams and floor joists.

(B) If any portion of the deck or porch floor is over 18 inches above grade it must have a 36-inch-high guardrail for residential and 42" high guardrail for commercial with intermediate members spaced not more than four (4) inches apart.

(C) Stairs over two (2) risers require the above guardrail/handrail requirement. (Lattice is an acceptable substitute for guardrail requirements.)

(D) Support posts must be anchored to the top of concrete piers. (Cannot be encased in concrete).

(A&E, Ch. I) (Major change BOD Approved 10-24-2014; Effective 1-1-2015)

## **FOOTING/FOUNDATION PLAN**

### **§ 71.45 FOOTING SIZES (MINIMUM).**

(A) Supporting frame: Eight (8) inches x 16 inches.

(B) Supporting brick veneer: Ten (10) inches x 18 inches.

(C) Column pier footings: Thirty (30) inches x 30 inches x 12 inches.

(D) Deck Piers: Eight (8) inches diameter x 42 inches deep.

(E) Masonry chimney footing: Twelve (12) inches thick.

(A&E, Ch. I) (Major change BOD Approved 10-24-2014; Effective 1-1-2015)

**§ 71.46 FOUNDATION THICKNESS (MINIMUM).**

- (A) Supporting frame: Eight (8) inches (unless using foam construction forms and a drawing stamped and sealed by a registered professional engineer is submitted).
  - (B) Supporting brick veneer: Ten (10) inches.
  - (C) Trench foundations may be used with slab construction - Width: eight (8) inches for frame; ten (10) inches for brick veneer. Depth: 42 inches.
  - (D) All wing walls must be reinforced with #5 re-bars. Wing walls are required under all concrete stoops/steps.
  - (E) New foundations must be doveled into existing foundations with four (4) #4 bars at each point of attachment.
- (A&E, Ch. I) (Major change BOD Approved 10-24-2014; Effective 1-1-2015)

**FLOOR PLANS**

**§ 71.60 GARAGE.**

- (A) Header size for 16-foot opening: three (3) (2" x 12")s, two (2) (2" x 14")s or two (2) (2" x 12")s with one-fourth (1/4) inch x 11-inch steel plate or LVL headers.
  - (B) All outlets to be on GFI circuit.
  - (C) If any portion of the second floor is over the garage, all walls, ceiling, beams, and columns must be covered with five-eighths (5/8) inch drywall, taped and sealed.
  - (D) A six (6) inch gas curb is required into house from garage; stairways leading down must have a six (6) inch gas curb around them along with handrails and guardrails.
  - (E) Door into house: Two (2) feet eight (8) inches wide, one (1) hour rated; with self-closing device.
  - (F) Garage slab: Four (4) inches of concrete; six (6) inches x six (6) inches #10 wire mesh, four (4) inches of stone and ten (10) mil vapor barrier.
  - (G) Any door leading to the outside (excluding overhead door) must have a separately switched interior and exterior light.
  - (H) Ceiling joist and roof rafters' size, spacing and direction.
  - (I) If ceiling is dry walled, an attic access with a light switched at point of entry is required. Minimum opening size - 18 inches x 24 inches.
  - (J) Pull downstairs are not permitted in garage where rated ceiling is required.
  - (K) A room containing a gas furnace or water heater cannot open directly into garage.
  - (L) Garage heaters require specs indicating heater is designed for the use being submitted
- (A&E, Ch. I) (Major change BOD Approved 10-24-2014; Effective 1-1-2015)

**§ 71.61 ROUGH FRAMING.**

- (A) All structural members, sizes and spans must be in accordance with the current Wall-Floor-Ceiling-Roof span tables in the 2015 Edition of the International Residential Code. All structural members must have manufacturer's grade rating stamp.
- (B) Cuts, notches, or holes bored in laminated veneer lumber, glue lam members or I-joist are not permitted beyond the manufacturers recommendations.

(C) Truss members are not to be altered in any manner without the submitted, stamped approval of a licensed professional engineer. "Hurricane Clips" and or tie-downs as specified per the manufacturer are required for all truss installations.

(D) Any structural member that has been cut beyond approved allowances must be properly reinforced.

(E) In combustible construction, fire-blocking shall be provided to cut off all concealed draft openings (both vertical and horizontal) and to form an effective fire barrier between stories, and between a top story and the roof space. Fire stopping materials must also be installed at soffits, garage to attic space and base plate and wall penetrations.

(F) Vapor barrier is required on exterior of sheathing and must be installed and taped per manufacturer's specifications.

(G) Porches, windows, doors, and door sills shall be properly flashed per the manufacturer's specifications.

(H) Bedrooms must have an egress in accordance with the current Window tables in the 2015 edition of the International Residential Code.

(I) A flight of stairs shall not have a vertical rise of more than 12 feet between floor levels and or landings.

(J) All attics shall be vented and have a minimum 22-inch x 30-inch access provided. Access not allowed in closets.

(K) Glazing in windows in hazardous locations must be tempered.

(A&E, Ch. I) (Major change BOD Approved 10-24-2014; Effective 1-1-2015)

#### **§ 71.62 CRAWL SPACE.**

(A) Floor: Four (4) inches of stone plus a ten (10) mil vapor barrier.

(B) Cross ventilation or mechanical ventilation is required.

(C) Access and light switched at point of entry. Minimum 24 inches x 24 inches.

(D) Beam and column sizes and locations.

(E) Size, direction and spacing of joists above.

(F) Minimum R-13 insulation required in floors above unheated crawlspaces.

(G) Minimum height of 24 inches is required between bottom of floor joists and top of grade inside crawl space.

(A&E, Ch. I) (Major change BOD Approved 10-24-2014; Effective 1-1-2015)

#### **§ 71.63 BASEMENT.**

(A) Floor: Four (4) inches of stone, ten (10) mil vapor barrier and four (4) inches of concrete.

(B) Beam, column and pier footing sizes and their locations.

(C) Size, direction and spacing of joists above.

(D) Metal window wells with drains tied into drain tile. (Minimum 36 inches projection window well required on escape windows.)

(E) At least one (1) escape window minimum 24-inch width x 30-inch height with sill no more than 44 inches above basement floor or provide second set of stairs. (Exiting through garage does not meet second remote exit requirements.)

- (F) Floor drain within five (5) feet of furnace and water heater tied to septic/ejector pit.
  - (G) At least one (1) switched light near furnace, etc., operated from stairway or entry to furnace room.
  - (H) No sump pumps or appliances may block escape window.
  - (I) Minimum of one (1) non-dedicated GFI receptacle required in unfinished basement.
  - (J) Three (3)-way light required to illuminate stairs.
  - (K) One hundred ten (110) volt smoke detector wired in series required.
  - (L) Below grade exits require floor drain, to sump pump, in landing.
  - (M) Passive Radon System design acceptable by Building Official.
- (A&E, Ch. I) (Major change BOD Approved 10-24-2014; Effective 1-1-2015)

#### § 71.64 FLOOR SLABS ON GRADE (HABITABLE ROOMS ONLY).

Four (4) inches of stone, ten (10) mil vapor barrier, two (2) inch x 24-inch rigid perimeter insulation (and at walk outs in basements) and four (4) inches of concrete with six (6) inch x six (6) inch wire mesh.

(A&E, Ch. I) (Major change BOD Approved 10-24-2014; Effective 1-1-2015)

#### § 71.65 HABITABLE FLOORS.

- (A) Size, direction and spacing of joists and rafters above ceiling or second floor.
  - (B) Cathedral ceilings: size, direction and spacing of roof rafters and ridge beams. Rafters must be deep enough to allow R-38 insulation and minimum one (1) inch air space.
  - (C) All rooms must be completely labeled as to their use.
  - (D) A handrail, as well as guardrails on all open sides, is required at all stairs over two (2) risers.
  - (E) All appliances (furnaces, water heaters, washers, dryers, etc.) must have at least 36 inch clearance in front for servicing.
  - (F) All attics must have access as well as switched light at the point of access.
- (A&E, Ch. I) (Major change BOD Approved 10-24-2014; Effective 1-1-2015)

#### § 71.66 TEAR-DOWN GUIDELINES.

- (A) **TEAR-DOWN** means a complete removal of foundation and house. If rebuilt within 1 year with foundation approval by Architect, foundation may remain.
- (B) A permit and fee (\$150/\$250) will be required for a tear down, fee may be waived by A&E Committee due to a hardship.
- (C) The current impact fee for new construction will apply.
- (D) All current septic codes will apply.
- (E) New homes must meet Appendix A, Appendix B or Appendix C of the current A&E Building Rules & Regulations.
- (F) All variances associated with a tear down lot will no longer apply.
- (G) All rules and regulations associated with the tear down will be addressed by the A&E Committee at the time of the permit.

(H) The use of a building for a tear down by the local Fire Department will be considered on a case-by-case basis. All laws, state codes and EPA permits will be addressed.

(I) Permit duration is three (3) months. Final inspection is needed before backfilling.

(J) If no construction within one (1) year; well needs to be capped and holding tank for septic needs to be decommissioned.

## **CHAPTER 72: LAKE CARROLL BUILDING RULES AND REGULATIONS**

### Section

#### *General Provisions*

- 72.01 Building Approval
- 72.02 Colors and Materials
- 72.03 LP Tanks
- 72.04 Adjacent Property
- 72.05 Platting/Replatting of Lots

#### *Specific Regulations*

- 72.15 Campground
- 72.16 Lot Plot Plans
- 72.17 For Permit Issuance and Completion of Construction
- 72.18 Private Sewage Disposal System
- 72.19 Sewage Disposal Regulations
- 72.20 Lake Carroll Septic Inspection/Pumping Schedule
- 72.21 Culvert Requirements and Driveways
- 72.22 Mandatory Inspections
- 72.23 Miscellaneous Building Requirements
- 72.24 Erosion Control
- 72.25 Modular Homes
- 72.26 Plumbing
- 72.27 Electrical Requirements
- 72.28 Shoreline Stabilization Policy
- 72.29 Residential Piers, Docks and Swim Platforms

#### *Accessory Buildings (Including, but Not Limited to Sheds, Beach Houses, Garages, Barns, Stables & Loafing Sheds)*

- 72.30 Sheds
- 72.31 Gazebos/Pergolas/Pavilions
- 72.32 Barns, Stables and Loafing Sheds
- 72.33 Beach Houses
- 72.34 Detached Garages
- 72.35 Decks
- 72.36 Fences
- 72.37 Occupancy Permit
- 72.38 Antenna and Towers
- 72.39 Satellite Dish

Lake Carroll Association, IL Code of Ordinances

- 72.40 Commercial Building Requirements and Specifications
- 72.41 Private Swimming Pools, Hot Tubs and Spas
- 72.42 Landscaping
- 72.43 Wells
- 72.44 LP Propane Tanks
- 72.45 Fuel Storage
- 72.46 PV Solar Panels

**Variance Policy**

- 72.55 Variances Generally
- 72.56 Setting Hearing or Meeting; Time Limitation
- 72.57 Notices
- 72.58 Variance Criteria

**GENERAL PROVISIONS**

- (A) Key Topography notes for Building at Lake Carroll
  - (1) Impervious surfaces not to exceed 40% of property area.
  - (2) Lake Carroll Pool Elevation Design is 740’
  - (3) Lake Carroll Flood Elevation Design is 746’

**§ 72.01 BUILDING APPROVAL.**

(A) No construction may be started until written approval and a permit has been obtained from the A&E Committee and posted.

(B) Provide three (3) sets of stamped plans and three (3) preliminary plot plans with permit application.

(C) One (1) set of your building plans, one (1) plot plan and a copy of the plotted survey will be retained by the A&E Committee. Two (2) additional sets will be returned to either you or your contractor. The two (2) returned sets will be stamped approved and you will also receive a formal letter of approval.

(D) The Building Inspector will meet with either the owner or the owner's contractor and will check stake out of the improvement on lot, and then issue your building permit. A permit must also be obtained from Carroll County prior to the start of construction, if the size of the improvement is greater than eight (8) feet X eight (8) feet. Or alters the footprint of the current building.

(E) DEMOLITION: Any plans for demolition must be included in any permit request. Plans must include how debris is to be handled and how land will be left.  
(A&E, Ch. II, § G)

**§ 72.02 COLORS AND MATERIALS.**

(A) Color is a very personal thing. Preference for a particular color is found in the clothes we wear, the furniture we buy and the cars we drive. Color is all around us and is ever changing, providing us with beauty and a variety. Nowhere is this more evident than in nature.

(B) Color should and must be factored into your house planning from the very beginning. Colors or finishes that detract from the natural setting may be grounds for disapproval of any application for construction at Lake Carroll.

(A&E, Ch. II)

### § 72.03 LP TANKS.

(A) Refer to “LP Tanks Addendum #2006-08” (See Appendix D) for tank options.

(B) If you elect to use L.P. gas, your tank must be placed where it can be conveniently accessed for maintenance and filling.

(C) The placement must be clearly indicated on the plot plan. All above ground tanks MUST BE SCREENED. The minimum screening is with four (4) x four (4) posts and lattice work, not to exceed five (5) feet in height. All tanks must be at least ten (10) feet from any structure. The screening method must be approved by the A&E Committee.

(A&E, Ch. II)

### § 72.04 ADJACENT PROPERTY.

All property owners of record must obtain written permission to use property other than the building site for access to construction site or any other purpose. This permission must be obtained prior to such use and filed with the A&E Committee. Violation of this policy will result in the issuance of a citation. A “stop order” will be placed on the job of record along with fines. All fines must be paid before the job of record will be allowed to proceed.

(A&E, Ch. II)

### § 72.05 PLATTING/REPLATTING OF LOTS.

(Motion at 6-24-2016 Board Meeting)

(A) GENERAL PROVISIONS:

(1) For all Lots in all Sections within the Lake Carroll Development, where a Lot or Lots have previously been made subject to a valid Contiguous Lot Agreement, a re-plat of only those Lots subject to the Contiguous Lot Agreement may be allowed into one (1) single, dues paying lot upon proper Petition of the Owner(s) and upon review by the A&E Committee and the approval of the Board of Directors.

(2) For all Lots in all Density Sections that are owned or otherwise acquired by the Lake Carroll Association, a re-plat of any Lots contiguous with each other may be allowed into one (1) single, dues paying lot upon proper Petition of the Lake Carroll Association and approved by the Board of Directors after review by the A&E Committee.

(3) The Board of Directors shall have the right to impose any restrictions or conditions in connection with the approval of any such re-plat Petition, including, without limitation, the requirement that the Owner must continue to pay all assessments, dues, costs and expenses imposed on each Lot that are included in any such re-plat.

(4) All Re-Plat Petitions shall include a non-refundable filing fee in the amount determined by the A&E fee structure.

(5) As a condition of all replat approvals by the Board of Directors, all assessments must be paid in full and are not refundable.

Lake Carroll Association, IL Code of Ordinances

(6) Sections 1,2,3,4,5,12,13,16,20 & 30. are defined as Density Sections.

(a) Up to three (3) originally platted lots may be combined by re-platting upon review by the A&E Committee and upon approval by the Board of Directors. Additional adjacent lot(s) may be re-platted upon review by the A&E Committee and Board approval as long as multiple dues are paid.

(b) Any addition to two (2) lots currently under Contiguous Lot agreement must be re-platted for the entire group.

(7) Section 17.

(a) Two (2) originally platted lots with a common boundary can be combined into one (1) lot by a re-plat upon review of the A&E Committee and approval of the Board of Directors.

(b) Any lots under Contiguous Lot Agreement must be re-platted for the entire group upon review of the A&E Committee and approval of the Board of Directors prior to the issuance of any permits for landscaping or construction.

(c) Approved replats in Section 17 one (1) acre or larger must pay multiple dues for each lot included on the re-plat.

(8) Sections 15, 18, 19, 21, 22, 23, 24, 25, 26, 27, 28, 29 & 31.

(a) Any originally platted lots with a common boundary, whose original size is larger than one (1) acre, may be included in a re-plat arrangement, but must pay separate dues for each lot included in the re-plat.

(9) In all sections, if any lots are under Contiguous Lot Agreement prior to January 1, 2016 and paying dues on one (1) lot only, the owner may NOT build across lot lines or on any adjacent lot unless all lots under the contiguous agreement are re-platted.

PROCEDURE (Find "Re-platting Application" in index).

(a) A request for the proposed re-plat must be submitted to the A&E Committee at least ten (10) days prior to their next scheduled meeting. Property owner's names for all lots involved in the re-plat must also be provided. Lot numbers should incorporate the original number with the letter R following the number (i.e. Lot 118 and Lot 119 becomes 119R).

(b) The A&E Committee will review the proposed re-plat and determine whether it meets the requirements for re-platting at Lake Carroll and will then notify the applicant of their findings if it does not meet the requirements. Upon review by the Committee, it will then be submitted to the LCA Board of Directors for review. After LCA BOD takes action on the request the applicant will be notified of the findings.

(c) Upon approval of the request, a final plat of the proposed re-plat must be prepared by an Illinois Professional Land Surveyor in accordance with the requirements of the Carroll County Subdivision ordinance and submitted to the Lake Carroll Board of Directors for final signing and transmitted to the Carroll County Plat Officer for recording.

(d) Lots owned by the Association may be considered for re-plat on a case-by-case basis, upon review of the A&E Committee and considering all circumstances involved, the committee will report to the Board of Directors their findings. The Lake Carroll Board of Directors may approve for the good of the membership.

(e) The Board of Directors shall have discretion to approve a re-plat of any lot or lots into a single lot on the express condition that assessments, dues, costs and expenses must continue to be paid by the Owner of each lot that is included in any such re-plat.



(10) Prohibited Re-Plats: Re-Plats shall not be allowed under the following circumstances.

(a) When, in the sole and absolute discretion and judgment of the Board of Directors doing so would create or has the potential to create a hardship to adjacent property owners.

(B) VACATION OF RE-PLATS:

(1) An owner may file a Petition for the vacation of a previously approved re-plat of Lots in accordance with the following:

(a) A Petition shall be filed with the A&E Committee and the Board of Directors using the proper form containing information and documentation prescribed by the A&E Committee and the Board of Directors.

(b) The Petition shall include a non-refundable filing fee in the amount determined by the A&E fee structure.

(c) As a condition of approval of a vacation of any such previously approved re-plat, the Owner shall be required to pay any and all Association annual assessments, costs and expenses for each Lot which accrued during the years that any such assessments, costs and expenses were abated as a result of the re-plat. In addition, the Owner must pay in full, any and all outstanding debts, obligations and liabilities owed to the Association.

(d) Prior to the A&E Committee's review of a Re-Plat Vacation Petition by a property owner, and prior to the Board of Directors acting on the Notice of the Petition, a copy of the Petition along with the hearing date and time, shall be provided to all adjacent property owners as specified and provided for in Sect. 72.55, 72.56, 72.57, and 72.58 of the Lake Carroll Rules and Regulations. All hearings shall be conducted in the manner prescribed in Sect. 72.55, 72.56, 72.57, and 72.58, giving all interested parties the opportunity to voice their opinion on whether or not the relief sought in the Petition should be denied, approved, or approved with conditions.

(e) The vacation of a previously approved re-plat may be denied by the Board of Directors for anyone (1) or more of the following reasons, which list is not to be construed either directly or indirectly as being all inclusive.

1. The Board of Directors determine that any such vacation would not be in the best interest of the Association as a whole.

2. The Owner is indebted to the Association and has not settled the Owner's debt in full, or that the Owner is not otherwise in good standing with the Association.

3. Improvements have been constructed across the previously re-platted Lot lines.

4. Where the petition is lacking in form, substance, or content.

5. Where the vacation of the re-plat would create additional Lots which are not part of the original re-platted Lots.

6. Where doing so would be a violation of the Association's governing documents.

7. When good cause is otherwise shown for the denial of the vacation.

8. Where the vacation would result in a reconfiguration of the original Lot or Lots dimensions, surface area or characteristics which differed from the originally platted Lot or Lots that were included in and part of the original re-plat.

(f) Plat of vacation needs to be filed with the Carroll County Recorder of Deeds.

(C) MISCELLANEOUS PROVISIONS.

(1) The Board of Directors shall have the right to waive any term or provision of these Rules and Regulations for good cause shown. In the event the Board of Directors elects to do so, the Board of Directors must make specific findings of fact setting forth the basis for such waiver.

(D) INTENT AND PURPOSE.

(1) It is the primary purpose and specific intent of this Rule to address, those high-density areas within Lake Carroll Development where conflicts can arise with the installation of well and septic systems.

(A&E, Ch. II) (M01.09.7/M01.10.4 (repeat of "GG" of A&E Rules & Regulations 1-2008))

## SPECIFIC REGULATIONS

### § 72.15 CAMPGROUND.

(A) An A&E permit is required to set a seasonal trailer camp or vehicle camp within the Lake Carroll Campground.

(B) The permit request must include a drawing of site and proposed location of trailer or vehicle camp.

(C) **Accessory Buildings:** (Need to be permitted by A&E Committee) Not to exceed 100 square feet with a six (6) feet high sidewall. Drawing of location and size must be submitted with permit application.

(D) For **all Campground Rules** including, but not limited to, **Definitions and Regulations**, refer to the **Lake Carroll Rules and Regulations**. See Chapter 55.

(A&E, Ch. II, § A) (Major changes BOD Approved 11-18-2011; Effective 1-1-2013; Major changes BOD Approved 10-18-2013; Effective 1-1-2014)

### § 72.16 LOT PLOT PLANS.

(A) (Drawn on “New Construction Survey with topographical lines”)

(B) “New Construction Survey” includes location of wells and septic of adjoining lots, if available, and drawn at the largest reasonable scale on a 24 inch x 36 inch sheet so that the plot plan can be added to it.

(1) Lot boundaries showing proposed location of all improvements complete with dimensions from lot lines. Dimensions are from edge of foundation or deck, whichever is closest to lot line. A maximum of a 24-inch roof overhang will be allowed. Show dimensions from adjacent road, side, and back lot lines (lakeside if applicable).

(2) Proposed septic system location and size as approved by the Carroll County Public Health including septic tank placement.

(3) Indicate existing tree removal (see Appendices A, B and C).  
(A&E, Ch. II, § B)

**§ 72.17 FOR PERMIT ISSUANCE AND COMPLETION OF CONSTRUCTION.**

(A) (1) The property must be staked out indicating the proposed home site. The stake out must be approved by the Building Inspector *before any excavation is performed*. Effective 3-1-1996 All approvals will require surveyor to identify the property lines closest to the house location and place a survey stake every 50 feet. These stakes must be in place prior to the issuance of the building permit. Excavators must keep these areas open to allow for proper inspection.

(2) Residential home permits are valid for one (1) year from the date issued or upon final inspection, whichever occurs first. The permit, once issued, needs to be posted so it is visible from the road, approximately 30 feet from road. Excavating prior to initial inspection and stake out is a cause for a stop order on construction and a possible fine to general contractor and/or property owner.

(3) All residential home approvals must be permitted and started within 90 days from A&E committee approval. A home not started will have permit canceled by A&E Committee. All fees except \$50.00 handling fee will be returned.

(B) (1) Completion of home including basic landscaping must be completed within 12 months from issue date of the building permit. Any construction not completed in 12 months requires an extended permit. An extended permit must be applied for prior to the original permit expiration. A new completion date shall be set. New home construction and additions permits can only be renewed three (3) times. One (1) six (6) month extension, and two (2) - one (1) month extensions. Failure to complete by this date may result in the forfeiture of your escrow deposit and possible daily fine impositions.

(2) Refer to A&E Fees & Penalties - § 70.16: Permit Fees, Permit Extension Fees, Penalty Fees and permit validity timeframes.  
(A&E, Ch. II, § C)

**§ 72.18 PRIVATE SEWAGE DISPOSAL SYSTEM.**

(A) All homes are required to install minimum of a four (4) bedroom septic system. Owners of lots that may not accommodate a four (4) bedroom system may request a variance from the “bedroom” standard but will be required to sign a legal document that no additional bedrooms will ever be added. This document will be recorded with the Carroll County Register of Deeds.

(POA Board approved August 1, 1997)

(B) See “Building at Lake Carroll” Septic and Well, § 71.29. Fee for recording will be added to permit fee.

(1) Design only after a proper soil evaluation test has been completed by a registered soils scientist.. Septic field must be at least 25 feet from lake.

(2) Submit proposed sewage disposal plans to the Carroll County Public Health and the A&E Committee. Plan must include relationships (and dimensions from lot lines and structures) to neighbors’ wells and septic.

(3) Approved sewage disposal plans, along with a copy of the letter of approval from the Carroll County Public Health must be on file with the A&E Committee before building permit is issued and construction can begin.

(4) All septic systems must be for a minimum of a four (4)-bedroom house size. If lot will accept conventional septic system, then a conventional system must be installed, except where it may render another lot unbuildable. A variance might be obtained for a one-fourth (1/4) acre lot if it is determined lot will not accept a four (4) bedroom septic system. Please check with Building Inspector for procedure.

(5) All septic systems require the approval of the Carroll County Public Health. This letter of approval must be received within 12 months prior to permit approval date.

(6) All septic tanks must be placed with easy access for pumping. Pumping access must be within 30 feet on a hill and 50 feet on flat ground.

(7) (a) Septic tank and field or bed must be installed simultaneously.

(b) No holding tanks or septic tanks, used as a holding tank, are allowed.

(8) If septic is changed from approved design or location, contractor is to submit revised plan within 15 days. If not submitted, contractor will be refused additional permits until revised plan is submitted.

(A&E, Ch. II, § D)

#### **§ 72.19 SEWAGE DISPOSAL REGULATIONS.**

(A) To protect sewage disposal systems from damage, all construction and road vehicles are restricted from driving over septic tanks, leaching fields or beds. Infractions are punishable by fines as follows: first offense \$500, subsequent offenses \$1,000 each. Septic fields must be staked as to location to identify for such protection.

(B) Special conditions which make it necessary to move equipment over restricted septic system areas must be submitted for review and approval of temporary load distribution design. Grass cutting equipment is exempt from this ruling. If a violation of this regulation should occur, a stop order will be issued. Any fines must be paid prior to allowing the job to continue.

(A&E, Ch. II, § E)

#### **§ 72.20 LAKE CARROLL SEPTIC INSPECTION/PUMPING SCHEDULE.**

(A) Each septic system will be scheduled to be pumped at four (4) year intervals regardless of size or use.

(B) Reminders will be sent to all that are to be in the current phase prior to March each year with a completion date of September 30, of the same year.

(C) Copy of report from contract pumper must be turned into the Association Office by September 30th of the same year to avoid a possible fine. Find “Septic Pumping Inspection Form” in Appendix D.

(D) Owners furnishing proof of compliance in the last three (3) years prior to the first time a section is scheduled will be placed on another schedule based on date of last pumping and so informed by mail as to their new schedule.

(E) Fine for non-compliance set at current A&E fine structure listed in the most current “Building Regulations”. (\$250 for failure to comply and \$25 per day until homeowner is in compliance.)

(A&E, Ch. II, § F)

**§ 72.21 CULVERT REQUIREMENTS AND DRIVEWAYS.**

(A) (Refer to § 74.03, A&E Policies, DRIVEWAYS & CULVERTS) Install culvert *prior* to start of any construction. Culvert to be minimum of 20 feet in length and 12 inches in diameter. Culvert to be covered with a *minimum* six (6) inches crushed rock. Culvert is to be galvanized metal type. Check with Building Inspector for correct size and alternate methods. (A&E, Ch. II, § H)

(B) *Concrete, Asphalt or Chip and Seal Driveway.* Requires a permit and fee in addition to the original building permit. Building Inspector’s approval of driveway location is required in all cases. Setbacks (side) according to the Covenants and Restrictions must be followed (See “Building at Lake Carroll”, § 70.01). Any variances requested may be granted by the A&E Committee and may require adjacent lot owner agreement.

**§ 72.22 MANDATORY INSPECTIONS.**

A list of mandatory inspections is attached to the building permit application. There are eight (8) required mandatory inspections prior to inspection for occupancy and/or final inspection. *Failure to obtain required inspections would result in a fine of \$250 for each infraction.*

(A&E, Ch. II, § I)

**§ 72.23 MISCELLANEOUS BUILDING REQUIREMENTS.**

(A) *Finished Lot Grade.* The top of the foundation must not protrude more than two (2) feet above the original grade level.

(B) *Unattached Garage.* Refer to Appendices A, B & C for size limitations.

- (1) No roll roofing on roofs or siding.
- (2) Design and color shall compliment home.
- (3) No toilets will be permitted.

(A&E, Ch. II, § J)

**§ 72.24 EROSION CONTROL.**

Erosion Control measures will be evaluated on an individual basis, according to property location and elevation. Prior to or during commencement of any Construction or Improvement, the property will be evaluated under the direction of the Building Inspector to determine whether Erosion Control measures are needed. All Contractors will be advised to use silt fences at all locations that might cause a silt problem at the time of construction. Erosion Control measures are mandatory to ensure the protection of our Lake from run off and to prevent contamination or damage to the Lake and adjacent properties.

(A&E, Ch. II, § K)

**§ 72.25 MODULAR HOMES.**

(A) The floor joist, ceiling joist and roof framing requirements do not apply to factory designed and built homes, contingent upon certification that loading meets local and International Codes. However, three-fourths (3/4) inch T&G flooring is required. Home must carry the *Modular Seal State of Illinois*. All plumbing must meet current *Illinois Plumbing Codes* in effect at the time of construction.

(B) All electrical installations shall conform to the provisions as defined in the *National Electrical Codes* in effect at the time of construction and have a minimum 200-amp electrical service.

(A&E, Ch. II, § L)

**§ 72.26 PLUMBING.**

Effective 3-1-1996, all construction will require the Illinois Department of Health Plumbing Inspector to inspect all plumbing - prior to pouring basement floors, prior to drywall installation and final plumbing inspection. The inspector may be reached at (815) 987-7511. All contractors must give a 48-hour notice to ensure prompt inspections. The best time to contact the inspector is at 7 a.m. All contractors must notify the Building Inspector when plumbing inspection has been done. Framing approval will NOT be granted until a plumbing inspection has been done.

(A&E, Ch. II, § M)

**§ 72.27 ELECTRICAL REQUIREMENTS.**

Property owners should take safety and their neighbors into consideration when installing exterior lighting. Mercury or Sodium vapor lights are strictly prohibited and are not allowed on residential property. As to the types and placement of other exterior lighting, property owners are encouraged to consult the suggested guidelines and recommendations from the New England Light Pollution Advisory Group that can be found in the “Good Neighbor Outdoor Lighting” section located in Appendix D of the Lake Carroll Association forms. All homes that have or will have a security system must be noted and logged in at the Association Office.

(A&E, Ch. II, § N) (Revised and approved 2-24-2017)

**§ 72.28 SHORELINE STABILIZATION POLICY.**

(A) All lakefront property owners must have stabilized their shoreline by 12-31-2000. (2-1999)

(B) General.

(1) All stabilized shorelines must be maintained in a manner to prevent soil erosion.

(a) Inspections are done in the fall annually.

(b) All work to be done prior to the 3rd Friday in October of the following year.

(c) Failure to bring shoreline into compliance; Property Owner will be assessed up to a \$1000 fine plus the price of the work and labor to bring the shoreline into compliance.

(2) NOTE:

(a) Creosote ties or treated lumber may not be used for stabilization of shoreline.

(b) A permit is required for all sections of this shoreline stabilization and maintenance policy.

(C) RIP RAP AND SHORELINE STABILIZATION: Rip Rap or other methods of stabilization must be installed from pin line to pin line (the entire shoreline of the property).

(D) Rip Rap: Shoreline stabilization shall be accomplished by the placement of rip rap, properly sized over geotextile fabric placed on a properly graded shoreline. Variances shall be granted for technical reasons only.

(1) Specifications: If the final graded shoreline slope exceeds four (4) to one (1), (Four (4) = horizontal with a one (1) foot rise) rip rap shall not be used for shoreline stabilization. If the final graded shoreline slope is between three (3) to one (1) and four (4) to one (1), rip rap used for shoreline stabilization shall meet the criteria of the IDOT RR#3. This criterion applies to all active areas of the lake (all areas other than no wake areas). If the final graded shoreline slope is less than four (4) to one (1) and the lot is within the active area of the lake, rip rap must be used per IDOT RR#3, having an average size of six (6) to ten (10) inches in diameter and shall not contain more than ten percent (10%) of fines. When not in an active area of the lake, where the final graded shoreline slope is between three (3) to one (1) and four (4) to one (1) crushed limestone having a size gradation of three (3) to six (6) inches may be used. Limestone must have the hardness of IDOT RR#3 requirement. Permit required.

(2) Stabilized Beach Area: Stabilized beach areas within the riprap shoreline shall be permitted provided the maximum width of beach does not exceed 40 feet. Beach areas shall be stabilized by the construction of concrete or stone retaining walls with exposed areas of retaining wall installed at 741-foot level (one (1) foot above 740-foot normal pool level) permit required. Also see Shoreline Stabilization Policy paragraph (E)(2) below.

(3) Access to Lake: Access to the lake, docks, lifts; etc. through a rip rapped shoreline shall be permitted by the construction of stairs. Stair width shall not exceed combined 12 feet. All stairs through rip rap must be constructed of concrete or cut stone - Permit required.

(4) Boat Ramp: Boat ramp through a rip rapped shoreline shall be permitted. One (1) boat ramp per lot. Maximum width shall be 12 feet. Constructed and properly designed of concrete - permit required.

(E) Seawall - Permit Required. All seawall plans must include start and finish dates and must be submitted and approved by the A&E Committee prior to the lowering of lake on November 1st of each year.

(1) Seawall may be constructed of concrete, building stone or stainless steel. All seawalls shall be installed with suitable footings and all seawalls shall have weep holes and proper drainage to relieve pressure behind the seawall. Refer to the following for active and no wake areas of lake.

(a) Weep holes shall be one (1) foot above normal pool level or at 741 feet.

(b) Minimum size of weep hole shall be one (1) inch.

(c) Maximum spacing of weep holes ten (10) feet.

(d) Seawall to be back filled with dirt to within three (3) inches of weep holes (740' – 9") then two (2) to three (3) inch rock to grade or top of wall.

(2) (a) Seawall in the active area of the lake shall be designed in a manner, which significantly dissipates wave energy. A Seawall that reflects wave energy shall not be used.

(b) The base of any seawall shall be a minimum of three (3) feet below normal pool elevation of 740 feet. The top of the seawall shall be a minimum of two (2) feet above normal pool. Top of the required footing shall be a minimum of three (3) feet below normal pool.

1. For straight vertical seawall in the active area of the lake, rip rap must be placed in front of base of seawall from 737 to 741-foot level. Geotextile fabric and other parameters in shoreline stabilization shall be used. Use six (6) to ten (10) inch rock with RR#3 IDOT hardness. This rip rap must continue to be maintained after installation.

2. For straight vertical seawall in the no wake area of the lake, place rip rap from 737 to 739-foot levels. The size of rip rap shall be three (3) to four (4) inches and of a hardness of RR #3 IDOT material. Geotextile fabric and other parameters shall be used. This rip rap must continue to be maintained after installation.

(c) Alternate Seawall (designed to dissipate wave energy).

1. Zigzag seawall: Maximum eight (8) feet long wall sections shall alternately be directed away from and then towards the lake shoreline at an angle of 30 degrees over eight (8) feet on a straight side (see illustration).

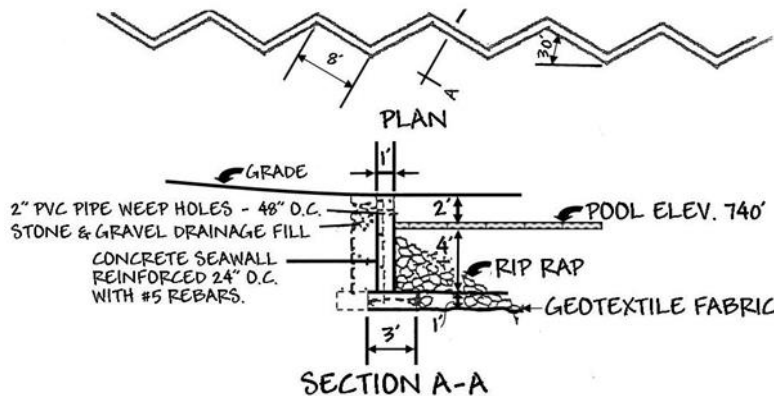

2. Sloped seawall: The top portion of the wall, from elevation 739 to its highest elevation, is angled away from the lake at a 30-degree angle (see illustration).

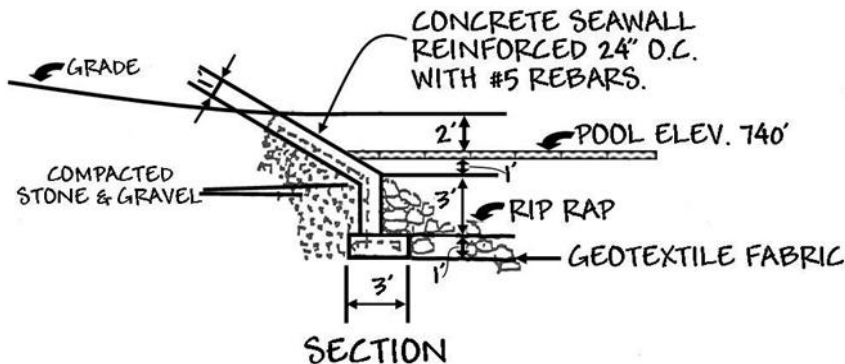

(A&E, Ch. II, § O) (1-11-1997)



**§ 72.29 RESIDENTIAL PIERS, DOCKS AND SWIM PLATFORMS.**

(A) (1) Piers and docks shall be made of steel, aluminum or treated lumber (treated lumber to be used above water only). Floating docks must use approved steel or aluminum pontoons or plastic-coated polystyrene floats specifically manufactured for floating docks. Drums of any type or un-coated formed plastics are prohibited.

(2) Piers and docks may include railings, benches, storage boxes and provisions for life preservers. Prohibited are boathouses, sheds, living quarters or roofed structures of any type projecting on to the lake. No private dock, pier, boat lift or swim platform shall extend more than 30 feet from shoreline into Lake. Nor shall any such structure be constructed without permit issued by the A&E Committee. All piers, docks, swim platforms shall be removed from the lake prior to November 1st each year. All piers and docks must have a minimum width of 36 inches. Maximum width for any residential dock or pier shall not exceed 96 inches. Minimum length is eight (8) feet and maximum length shall not exceed 30 feet into the lake from the existing shoreline including ramps.

(3) Swim platforms shall be a maximum of eight (8) feet by eight (8) feet and must not extend more than 30 feet from shoreline.

(4) All piers, docks, boat lifts and/or swim platforms projecting into the lake must have affixed reflective devices or tape of eight (8) square inches of surface on all sides visible from any direction on the lake. Maximum of two (2) piers or docks per lot are permitted. Two (2) docking stations may be permitted by other LC members, provided that member has the lot owner's permission and are registered with the Association Office. (Docking/Watercraft registration forms are available at the Association Office.) All piers, docks, boatlift and swim platforms must have lot and section numbers attached that are visible on lake end of structure. No decks or piers shall cantilever the shoreline or seawall. Property owners with private docks, piers, boat lifts, swim platforms not adhering to these specifications will be required to remove said structure from Lake Carroll and/or be fined. All piers and docks in bay areas shall have placement approved each year by A&E Committee prior to any installation to insure no disruption of bay access to other property owners.

(B) **GREENWAY AND COMMON AREA PIERS AND DOCKS:** Piers and docks on Greenway or common areas must have a minimum width of 36 inches and a maximum of 51 inches and shall not extend more than 30 feet from shoreline into the lake. Piers and docks shall be made of steel, aluminum or treated lumber (treated lumber to be used above water only). For those members participating in the program where the Association assumed ownership of the pier or dock and provides the insurance, the pier or docks shall be manufactured by a commercial manufacturer of waterfront docks and pier products. NO homemade piers or docks shall be allowed in the program. Floating piers or docks must use approved vinyl, aluminum, foam filled rotationally molded polyethylene or coated polystyrene floats. All drums of any type, treated lumber, or un-coated plastics are prohibited. Docks and piers constructed with Greenway or common areas access must be re-permitted each year. All such docks and piers shall be installed in accordance with greenway site plans. Before seeking a permit, please refer to "Greenways and Common Areas" of the most current Lake Carroll Rules and Regulations, § 54.05. No lake front property owners may install docks on greenway or common areas. No boatlift, railway, or permanent boat storage device of any type may be installed on any greenway or in conjunction with a dock or pier. No swimming floats or diving platforms shall be installed on any greenway accessible dock or pier.

(Amended 1-17-2004)

(C) **RESERVED AREA DOCKS** (*Shoreline docks in East Marina*): Docks in Reserve Area must have a minimum width of 36 inches and a maximum width of 51 inches and shall not extend more than 30 feet from the shoreline into the lake. Construction must be of steel or aluminum. Floating docks must use approved vinyl, aluminum, foam filled rotationally molded polyethylene or coated polystyrene floats. All drums of any type, treated lumber, or un-coated plastics are prohibited. Docks constructed with Reserve Area access must be re-permitted each year. All docks shall be installed in accordance with Reserve Area site plans. No lake front property owners may install docks in a Reserve Area. Steps (required) (*See "Treads and Risers"*) and docks (*See "Residential Piers, Docks, and Swim Platforms"*) installed in the reserve area must be by code plus docking cleats on both sides and approved by the Building Inspector. All unsafe steps must be replaced. Steps and docks will be inspected from time to time to ensure safety. ALL DOCKS MUST BE REMOVED FROM THE RESERVE AREA PRIOR TO NOVEMBER 1ST OF EACH YEAR.  
(A&E, Ch. II, § P) (Lake Carroll Association Board Approved 4-23-1993)

### § 72.29.1 LAKE STRUCTURES, DEBRIS, AND BUOYS.

- (A) Members are strictly prohibited from putting any structure or debris into the lake (i.e., rock reefs, fish structure, grass clippings, trees, dirt, concrete blocks, etc.).
- (B) Members will not deploy or anchor any orange buoys into the main body of the lake as this could interfere with the association's navigational buoys already in place
- (1) Personal Buoys may be any color other than orange, and must have lot and section numbers on them.

## ACCESSORY BUILDINGS (INCLUDING, BUT NOT LIMITED TO SHEDS, BEACH HOUSES, GARAGES, BARNs, STABLES & LOAFING SHEDS)

### § 72.30 SHEDS.

- (A) Sheds may not be constructed prior to the construction of a home on that lot.
- (B) The A&E Committee's approval of the design, materials, color and location on the lot is required. The building must be on back half of lot.
- (C) Shed size limits:
- (1) Maximum size of a shed 288 square feet.
  - (2) The height shall not exceed eight (8) feet on sidewalls.
  - (3) Maximum overall height of structure not to exceed 20' measured from lowest grade elevation to highest projection.
- (D) **No Dirt Floors**, site location must allow for proper drainage.
- (E) Design and color should complement the home.
- (F) Plumbing is allowed (no toilets).
- (G) Variances on setbacks may be allowed by the A&E Committee.  
(April 23, 2005, M05.04.13)
- (H) For Lakefront accessory buildings there must be a 15-foot setback from lakefront property line that is surveyed and marked.  
(A&E, Ch. II, § Q) (LCA Board approved 11-8-2018)

- (I) Slab and/or gravel pad detail required. Anchoring detail required.
- (J) Floor plan and elevation details required.
- (K) All electrical and plumbing defined and identified.

**§ 72.31 GAZEBOS/PERGOLAS/PAVILIONS.**

**(A) Lots without a home.**

(1) Gazebos, no more than 12 feet across the middle in either direction, may be permitted prior to a home being built.

(January 11, 2002, M02.01.02)

- (a) Maximum floor area not to exceed 144 SqFt.
- (b) Height shall not exceed eight (8) feet on sidewalls.
- (c) Maximum overall height of structure not to exceed 20' measured

from lowest grade elevation to highest projection.

(2) Prior to the start of construction all gazebo design, materials and location on the lot must be approved by the A&E Committee. Permit required.

(3) Sides below floor level must be enclosed.

(4) Sides above floor level may be partially enclosed and/or screened in, but under *NO circumstances*, for structures built prior to home construction, will windows and/or combination windows, plastic, plywood, cardboard, etc. be allowed to enclose those sides.

(5) Gazebos must not be used for sleeping quarters or for storage sheds.

(6) For lakefront improvements there must be a 15-foot setback from lakefront property line that is surveyed and marked.

(7) No Plumbing allowed.

**(B) Lots with a home.**

(1) Gazebos on lots less than one (1) acre in size may

- (a) Have a maximum floor area of 144 SqFt.
- (b) The height shall not exceed eight (8) feet on sidewalls.
- (c) Maximum overall height of structure not to exceed 20' measured

from lowest grade elevation to highest projection.

(2) Gazebos on lots over one (1) acre in size may

- (a) Have maximum floor area of 400 SqFt.
- (b) The height shall not exceed eight (8) feet on sidewalls.
- (c) Maximum overall height of structure not to exceed 20' measured

from lowest grade elevation to highest projection.

(3) For Lakefront improvements there must be a 15-foot setback from lakefront property line that is surveyed and marked. (A&E, Ch. II, § R)

(4) Plumbing is allowed (no toilets).

**§ 72.32 BARNs, STABLES & LOAFING SHEDS.**

BARNs, STABLES AND LOAFING SHEDS ARE ALLOWED ONLY ON RANCHETTE OR EQUESTRIAN LOTS AS DESIGNATED IN THE COVENANTS.

(A) Barns, stables & loafing sheds may not be constructed prior to the construction of a home on that lot.

(B) The A&E Committee's approval of the design materials, color and location on the lot is required. Design and color should complement the home.

(C) An exterior frost-free water hydrant is allowed. No other plumbing is allowed.  
(A&E, Ch. II, § T)

(D) Maximum overall height of structure not to exceed 20' measured from lowest grade elevation to highest projection.

### § 72.33 BEACH HOUSES.

(A) Beach Houses may not be constructed prior to the construction of a home on that lot. Beach Houses will be required to have the same documents as new construction and will be reviewed as new construction.

(B) The A&E Committee's approval of the design, materials, color and location on the lot is required. The building must be located on back half of lot.

(C) Maximum floor area of Beach House

(1) On lots less than one-half (½) acre is 400 SqFt footprint and 500 SqFt of total enclosed floor space. Maximum floor area on lots larger than one-half (½) acre is 600 SqFt footprint and 750 SqFt of total enclosed space, with minimum shoreline frontage of 50 feet. Maximum floor area on lots larger than one (1) acre is 800 SqFt footprint and 1,000 SqFt of total enclosed space, with minimum shoreline footage of 75 feet. All sizes subject to review of survey, set-backs and surrounding conditions. Total impervious surfaces shall not exceed 40% of the lot area.

(D) Maximum sidewall height of 8' and maximum overall building height not exceed 20' from lowest grade elevation of beach house to highest projection

(E) A minimum of a four (4) inch floating slab is required for foundation.

(F) Design and color should complement the home. Siding, Trim, Roofing colors to be indicated on plans.

(G) Plumbing is allowed with submittal of proper design of water/sewage pumping or disposal method. All plumbing to be designed by licensed professional and included on drawings.

(H) Beach Houses must comply with the 15-foot setback from property line that is surveyed and properly marked.

(I) Beach Houses may not be used as a temporary or permanent residence, or as sleeping quarters.

(LCA Board approved 11-8-2018)

(J) Plat of Survey indicating dimensions from lot lines, set-backs, septic system and well. Impervious surface calculation to be provided.

(K) No floor to be constructed lower than an elevation of 743' (3' above Lake Carroll Pool Level.) Elevation to be indicated on stamped drawings and/or current survey.

**NOTE: Please keep Pool Level (740') and Flood Stage Level (746') in mind with all building construction.**

(L) Stamped and Signed drawings by a current licensed State of Illinois architect or structural engineer will be required for all beach house projects. Drawings will be sent out for Code Compliance prior to A&E Committee review.

(M) Any electrical work to be defined and included on drawings.

**§ 72.34 DETACHED GARAGES.**

- (A) Detached Garages may not be constructed prior to the construction of a home on that lot.
- (B) The A&E Committee's approval of the design, materials, color and location on the lot is required.
- (C) Total impervious surfaces shall not exceed 40% of the lot area. All sizes subject to review of survey, setbacks, and surrounding conditions. Garage to be located on a plot of survey indicating all applicable setbacks, well and septic location and Impervious surface calculation.
- (D) A minimum of a four (4) inch floating slab is required for foundation.
- (E) Design and color should complement the home. Siding, Trim, Roofing colors to be indicated on plans.
- (F) Plumbing is allowed (no toilets).  
(LCA Board approved 11-8-2018)
- (G) Maximum overall height of structure not to exceed 20' measured from lowest grade elevation to highest projection.
- (H) Slab pad detail required. Anchoring detail required.
- (I) Floor Plan and Elevation Details required.
- (J) All electrical and Plumbing defined and Identified

**§ 72.35 ATTACHED DECKS.**

ALL REMODELING (STRUCTURAL CHANGES) AND CONSTRUCTION OF A DECK NEED A PERMIT.

**(See latest edition of the International Residential Code and DCA-6)**

(Require species and grade of lumber on all plans submitted.)

- (A) A&E Committee's approval of all deck designs, materials, and location is required. Indicate design materials and colors on plans.
- (B) Sides, under decks, must be enclosed if used for storage area.
- (C) All decks on lots smaller than one (1) acre shall have a maximum surface area of 800 square feet.
- (D) All decks on lots larger than one (1) acre shall have a maximum surface area of 1,000 square feet.
- (E) Whenever a difference in the elevation exists of 18 inches or more between ground level and top of deck floor, a safety railing with balusters is required on that side. Stair handrail required when 2 or more stair risers. Dimensioned stair and handrails are required.
- (F) Maximum spacing between railing balusters is four (4) inches.
- (G) All decks attached to dwellings must be supported by frost-free footings. Sizing of footings and piers to be followed as described and listed in DCA-6.
- (H) Post support foundation: Maximum height to equal six (6) inches below basement floor for walkouts. May be up to seven and three-fourths (7-3/4) inches below basement floor, but in all cases equal to the level of a poured concrete patio. In no case may the bottom of the wooden support post(s) be below grade or embedded within the post support foundation.  
(A&E, Ch. II, § S) (LCA Board approved 11-8-2018)
- (I) Provide a Plat of Survey indicating applicable dimensions from lot lines, set-backs, septic system and well.

(J) Provide Floor Plan and elevations including footing, pier or foundation specifications/elevations. Indicate joist sizing, spacing, and direction. Single level attached deck 14' above grade and lower are the only structures covered by DCA-6.

(K) Enclosed, partially enclosed, 3 season room, covered deck, multi -level decks, Detached decks, etc are not covered under DCA-6. Any of the above listed structures are required to have plans stamped by licensed professional architect and/or structural engineer and in compliance with the current IRC being used as stated in LCA Building rules and regulations.

### § 72.36 FENCES.

(See Appendix C for further information on fencing on “Ranchette” or “Equestrian” lots.)  
No lot fences are permitted except as follows.

(A) The A&E Committee’s approval of the design, materials, color and location upon lot, prior to construction, is required.

(B) Temporary fences for protection of new trees and shrubs or winter “cover” fences are at the discretion of the A&E Committee.

(1) Color must be galvanized steel, black, or green. (No orange or iridescent colored).

(July 1, 2007)

(2) Must not be erected prior to Labor Day weekend each year.

(3) Must be removed by Memorial Day weekend each year. Exception: Galvanized or steel fencing may stay in place year around with permission of the Building Inspector and/or A&E Committee.

(C) Dog runs are at the discretion of the A&E Committee. Fencing must be of a nature so as not to “stand out” to neighbors in the area. i.e. chain link should be black so it won’t “stand out”. Fencing is not to go beyond confines of house and not to be seen from front of house.

(A&E, Ch. II, § U)

### § 72.37 OCCUPANCY PERMIT.

An occupancy permit is required *prior* to occupying a dwelling. A list of requirements may be obtained from the Building Inspector. *Failure to obtain the proper occupancy permit will result in an imposed fine of \$250 Plus \$25 per day of violation for the homeowner.* A well construction report and a report on the water quality must be obtained prior to an occupancy permit being issued. (Copies must be furnished to the A&E Committee.)

(A&E, Ch. II, § V)

### § 72.38 ANTENNA, TOWERS, AND FLAGPOLES.

(A) One (1) tower on the property for the use of radio, TV or ham radio is allowed.

(B) May be free standing or attached to dwelling.

(C) Maximum of 40 feet, ground level to top of tower at tower location - permit required.

(D) Construction must be reviewed and permitted by the A&E Committee.

(E) In addition a TV antenna may be mounted on roof of dwelling. Roof mounted antenna under 12 feet in height requires no permit.

(A&E, Ch. II, § W)

(F) Provide Plot of Survey indicating location of Antenna, Tower, or Flagpole and identify all setbacks and lot lines as applicable for section location.

#### § 72.39 SATELLITE DISH.

(A) Thirty-six (36) inches or less satellite dish attached to dwelling requires no permit.

(B) Larger than thirty-six (36) inch satellite dish and equipment needs a permit for A&E approval.

(A&E, Ch. II, § X)

(C) Thirty-six (36) inches or less satellite dish mounted on a pole/post detached from dwelling requires no permit if under 12 feet in height, otherwise section 72.38 will apply were applicable.

#### § 72.40 COMMERCIAL BUILDING REQUIREMENTS AND SPECIFICATIONS.

(A) To be approved on an individual basis.

(B) To be in accordance with all national building codes.

(C) Setbacks non-residential:

(1) All buildings must be 50 feet from the front property line or any road.

(2) No sign shall be placed within 30 feet of the front property line or any road. (Maximum size see sign Policy §§ 73.01 and 73.02 for details).

(D) No gasoline sales will be permitted without special use permit by committee and Association Board.

(A&E, Ch. II, § Y)

#### § 72.41 PRIVATE SWIMMING POOLS, HOT TUBS AND SPAS.

(A) General: Pools used for swimming, hot tubs, spas and bathing shall conform to the requirements of this section provided that these regulations shall not be applicable to any such pool less than 24 inches deep, except when such pools are equipped with a water recirculating system or involve structural materials. Wading pools as defined are exempt.

(B) **WADING POOL.** Means a pool intended only for small children. It is not used for swimming or instruction in swimming. The maximum depth is less than 24 inches.

(C) **Plans and permits:** A swimming pool or appurtenances thereto shall not be constructed, installed, enlarged, or altered until plans have been submitted and a permit has been obtained from the A&E Committee. The approval of all local county and state authorities having jurisdiction over swimming pools shall be obtained prior to receiving a permit from the A&E Committee for a permit. Copies of the approvals shall be filed as part of the supporting data for the permit application. Plans shall accurately show dimensions and construction of the pool and appurtenances and properly established distance to lot lines, buildings, walks, fences, as well as details of the water supply system, drainage, and disposal systems. Detailed plans of structures, vertical elevations and sections through the pool showing depth shall be included. Pool depth is

the distance between the pool floor and the top of the perimeter wall or perimeter overflow system lip.

(D) Safety: Everyone owning a swimming pool that contains 24 inches or more of water in depth at any point (even during construction), shall erect and maintain thereon an adequate enclosure surrounding the pool area. See Enclosure in paragraph (E) below for more details.

(E) Enclosure: The enclosure shall extend not less than four (4) feet above ground. All gates shall be self-closing and self-latching with latches placed at least four (4) feet above ground. The enclosure shall be constructed as to prohibit the passage of a sphere larger than four (4) inches in diameter through any opening in or under any fence. The entire barrier, including doors and gates, shall be at least four (4) feet high measured on the inside and outside and shall not provide ready footing for climbing. No fence shall be located, erected, constructed, or maintained closer to a pool than three (3) feet. The wall of a house or building faced to a pool may be used as a portion of such fence. At least a temporary enclosure without any openings except for a gate shall be in place prior to any water being placed in pool. Agreement must be made with Building Inspector as to what will be allowed as a temporary enclosure.

(F) Alternative Device: A natural barrier, pool cover, or other protective device approved by the A&E Committee shall be acceptable as long as the degree of protection afforded by the substituted device is not less than the protection afforded by the enclosure, gate and latch described herein.

(G) Permit Required/Fee: The application shall be on form provided by the A&E Committee and shall be accompanied by plans drawn to scale (one-fourth (1/4) inch per foot) showing the following:

- (1) Pool dimensions including depth.
- (2) Location of pool on lot, distances from lot lines, structure, septic field, and septic tank. Use lot survey to indicate all dimensions and structures. Pool floor structure to be at minimum of 746' elevation (746' is Lake Carroll established flood level)
- (3) Fencing. See "Landscaping" (new shrubbery), § 72.42 and "Tree Removal", Appendices A, B & C.
- (4) A fee of \$25 will be charged for each pool permit.

(H) Penalty: Any person violating any provision of this regulation shall be fined not less than \$250 nor more than \$500 for each offense. A separate offense shall be deemed committed on each day during on/or which violation occurs or continues.  
(A&E, Ch. II, § Z)

(I) Provide complete electrical plans indicating equipment power, lighting, grounding, and bonding as required by current code. The location of noise producing equipment should be considered in respect to surrounding property owners.

## § 72.42 LANDSCAPING.

All professional landscaping shall require a permit with applicable fee.

(A) All landscaping must be kept within the property lines. No plantings are allowed in the road easement. Projected mature tree driplines must be kept within the property lines, even if farther than setback lines.



(B) Waterfront homes may apply for a temporary watering permit to draw from the lake to establish a new lawn. A permit is to be obtained from the A&E Committee with a fee of \$50 and is good for six (6) weeks.

(C) When a new finished grade is to be established a permit is required.

(D) Tree removal (see Appendices A and B).

(A&E, Ch. II, § AA)

(E) Landscape steps that are constructed with materials that are level with the surrounding surface shall not require handrails or intermediate platforms.

(F) Landscape steps that are constructed as carpenter built or prefab steps/landings which have an elevation of more than 18 inches above the surrounding surface must have handrails on at least one side and intermediate landing every 14 steps.

(G) All retaining walls must be installed to manufacturer's specifications. When submitting a permit application for retaining walls, manufacturer's specifications and installation instructions or certification by an Illinois Registered Structural Engineer must be included.

(LCA Board approved 11-8-2018)

(H) All permitted landscaping work needs to have plat of survey indicating location of work taking place, dimensioned with all appropriate setbacks, drip lines of trees, walkways, retaining walls, firepits, above grade structures etc.

#### § 72.43 WELLS.

(A) The A&E Committee's approval of all well locations is required. Said location must be verified prior to drilling.

(B) All well drillers shall, within ten (10) days of drilling a well, furnish a construction report on the well (same report sent to the state). This report will be placed in the property owners' file. Effective 11-3-1995 a satisfactory laboratory report on water quality for coliforms and nitrates must be furnished to the A&E Committee prior to occupancy. After 12-1-1995, all wells must be a minimum of six (6) inches in diameter and cased into shale and grouted.

(A&E, Ch. II, § BB)

#### § 72.44 LP PROPANE TANKS.

(Please also refer to Appendix D for LP Tank Options).

May be one (1) of the following.

(A) Buried.

(B) Screened or fenced and painted a light earth tone color.

(C) Minimum screening four (4) x four (4) treated posts and lattice. Not to exceed five (5) feet in height.

(D) Tanks must be screened before occupancy permit will be issued.

(E) LP dealers shall contact the Building Inspector prior to the setting of any LP tank for a proper location.

(F) LP Tanks (100-pound tanks) in the Campground must have stabilizing stands that are provided by the Association. Smaller LP tanks must also be tied down to prevent shifting.

(A&E, Ch. II, § CC)

**§ 72.45 FUEL STORAGE.**

(A) Commercial use gasoline and diesel fuel tanks, either buried or above ground, are *prohibited, unless specifically permitted.*

(A&E, Ch. II, § DD) (Lake Carroll Association Board approved 1-1-1992; LCA Board approved 11-8-2018)

(B) Gasoline, diesel, fuel oil, kerosine, bio-diesel fuel storage tanks either buried or above ground are prohibited on any residential use property.

**§ 72.46 PV SOLAR PANELS.**

(A) PV Solar Panels (Permit Required)

(1) Installation to be undertaken by a licensed electrical contractor.

(2) Installation to comply with the requirements of the International Residential Code.

(3) Installation to comply with the manufacturer's instructions, the National Electrical Code and Underwriters Laboratories product safety standards such as UL 1703 (PV modules) and UL 1741 (Inverters).

(4) A current State of Illinois licensed architect or structural engineer shall deem in writing that the existing roof structure is adequate to support all solar equipment being installed on said structure.

(5) Finished installation shall not extend more than 18 inches above the roof surface.

(6) Systems must have positive attachment to the roof structure (rather than a ballasted system).

(7) Ground mounted panels must be specifically requested in the permit application with justification as to why roof mounted panels will not work.

**§ 72.47 TEMPORARY STRUCTURES.**

(A) No temporary structures such as greenhouses, shipping containers, moving containers, etc., shall be placed on a lot without written consent by the A&E Committee.

(B) All criteria related to a temporary structure are at the discretion of the A&E Committee.

**VARIANCE POLICY**

**The Association's Covenants allow The A&E Committee to grant reasonable, variances or adjustments based on any unnecessary hardship and that the variance requested is not materially detrimental or injurious to Owners of other lots.**

**§ 72.55 VARIANCES GENERALLY.**

When a variance is requested or a determination of need for a variance by the A&E Committee is made, the procedures set forth in this section shall be followed. Only owners in

good standing may apply to the Committee for a variance. The variance may pertain to setbacks, size or shape of building structures, additions and remodels. (A&E, Ch. II, § EE)  
(A&E, Ch. II, § EE)

#### **§ 72.56 SETTING HEARING OR MEETING; TIME LIMITATION.**

When the provisions of this Policy require a Lake Carroll Association hearing or meeting in connection with any application filed pursuant to this Policy, the body or committee charged with conducting the hearing or meeting shall, upon receipt of a properly completed application and fee, as determined by the Lake Carroll Association Board of Directors from time to time, fix a reasonable time and place for such hearing or meeting; provided, however, that such hearing or meeting shall be commenced no later than 30 calendar days from the date of the formal application. This meeting or hearing shall be concluded no later than 60 days following the submission of subject application, unless the applicant shall agree to an extension or unless the hearing meeting agenda of the body is completely committed during that time.

(A) The office staff receiving said application for a variance shall prepare and forward all documents pertaining to the request to the committee or body charged with conducting said hearings prior to their next regularly scheduled meeting.

(B) When the applicant files the proper completed documentation and fee requesting a hearing, the representative of the committee or body conducting said hearing or meeting will assign a hearing date (pursuant to paragraph (A) above) and forward this information along with the pertinent documentation to the applicant, committee, or body as notification.  
(A&E, Ch. II, § EE1.)

#### **§ 72.57 NOTICES.**

(A) *Building Inspector to give notice.*

(1) The Building Inspector shall cause notice to be given to the Lake Carroll Association of hearings and meetings pursuant to a formal application for a variance(s) in the following form and manner.

(2) Once the date for the hearing has been assigned, the Building Inspector shall cause to be posted announcements at the Lake Carroll Association website and postings at the two (2) information boards at the formal entrances to the Lake Carroll property complex.

(B) *Applicant to give notice.* The Applicant, upon receiving the hearing date shall provide notice in the following form and manner.

(1) The applicant shall cause notice by posting a four (4) foot wide by two (2) foot high sign with black three (3) inch block letters on a white background on the property affected with all of the information in paragraph (C) below, Content of Notice. This sign shall be placed on the property in a location that is visible from the Lake Carroll road the property is addressed to. This sign shall not be located in any easement near the road surface.

(2) The applicant shall send by United States Postal Service Certified Mail, return receipt requested, notification of a formal application seeking a variance, to all property owners within a 250-foot radius of the property seeking the variance.

(3) The office staff shall provide the names and addresses of these property owners upon request.

(4) The applicant shall return all receipts of the sent notifications to the Building Inspector's office not later than seven (7) days prior to the hearing or meeting date. This includes all delivered and undelivered notifications. If the applicant fails to send notification to all property owners affected in paragraph (B)(2) above, the hearing shall be postponed, and the applicant will be required to reapply for the variance and hearing date.

(C) Content of notice. All notices and signs shall include the date, time and place of such hearing or meeting, a description of the matter to be heard or considered (including a plot plan, scope of work with dimensions), and address or particular location of subject property. The Building Inspector's approval of all required notice material is required prior to its distribution.

(D) Persons entitled to notice.

(1) By mail or personal delivery by the Building Inspector's office to the applicant and, if a specific parcel is the subject of the application, to the owner of the property.

(2) By certified mail, return receipt requested, to all property owners as described in paragraph (B)(2) above, by the property owner or his or her legal representative or agent, that shall have filed the formal request.

(3) By mail, personal delivery, or interdepartmental delivery from the Building Inspector's office, to the Lake Carroll Association General Manager, Board of Directors, Committees, Departments, Officials, Consultants, and others as determined by the Building Inspector.

(A&E, Ch. II, § EE2.)

## § 72.58 VARIANCE CRITERIA.

THE FOLLOWING CRITERIA WILL APPLY IN REVIEWING REQUEST FOR A VARIANCE. THE OWNER SEEKING THE VARIANCE MUST DEMONSTRATE AND ESTABLISH THE FOLLOWING:

(A) **HARDSHIP** - The current rules will cause an unnecessary hardship, either by creating a physical challenge for standard construction method or have excessive monetary implications to the Owner.

(1) The purpose of the variance is not based primarily upon the desire to enhance the monetary value of the property.

(2) The purpose of the variance is not based primarily upon the desire to change or circumvent a specific LCA rule.

(3) The physical surroundings shape and/or topographical condition of the property prevents compliance with the LCA governing documents and/or causes the Owner substantial financial hardship above and beyond the standard construction cost.

(4) The property in question cannot yield a reasonable return if permitted to be used only under the conditions allowed by the governing documents of the Association.

(5) A denial of the requested variance would potentially allow for the creation of more adverse or unintended use or improvement of the property.

(6) A denial of the requested variance would unreasonably deprive the property owner of the use and enjoyment of the property.

(B) **ESSENTIAL CHARACTER & IMPACT OF NEIGHBORHOOD** - The Variance requested will not:

- (1) Negatively impact the surrounding neighbors or alter the essential character of the area or neighborhood.
- (2) Impair an adequate supply of light and air to adjacent property.
- (3) Substantially increase the hazard from fire or other dangers to the property or adjacent property.
- (4) Impair the health-safety-general welfare of the Association, its members or general public.
- (5) Diminish or impair property values within the surrounding area.

**(C) VARIANCE GRANTED**

- (1) A variance granted shall be the minimum variation that will make possible the reasonable use of the land, building or structure.
- (2) A variance granted shall only be for the specific use requested. It shall be recorded with the Association for said property and not apply to any other portion of the property or adjacent properties.
- (3) A variance granted shall remain with the property and is transferable to new ownership, provided that any renovations or repairs do not change the size and configuration of the land, buildings, or structures as granted by the variance. If changes are required, the owner must apply for a new variance.
- (4) Variance Appeals: Any applicant requesting a variance from the A&E Committee shall have the right by appeal to the LCA BOD from any decision of the Committee within 30 days after the entry of such decision.
- (5) Also, any neighbor notified in the variance 250-foot distance requirement shall have the right to appeal to the LCA BOD any decision of the Committee within 30 days after the entry of such decision.

## **CHAPTER 73: OTHER ARCHITECTURAL AND ENVIRONMENTAL CONTROLLED ISSUES**

Section

### *Sign Policy*

- 73.01 Non-commercial signs
- 73.02 Commercial signs
- 73.03 Political Campaign Signs

*(All signs require A&E approval.)*

## **SIGN POLICY**

### **§ 73.01 NON-COMMERCIAL SIGNS.**

- (A) No person except the declarant (Lake Carroll Association) shall erect or maintain upon any lot or improvement any sign or advertisement unless prior approval is obtained from the A&E Committee.
- (B) *Policy:* All signs placed in Lake Carroll require a permit. An application for such permit must be submitted to the A&E Committee for approval. The application must include plot

plan of lot showing location of sign, drawn to scale, sketch of design including colors, height and type of material to be used and landscaping.

(1) "For Sale" sign needs to pertain to lot on which the sign is being posted.

(C) General Contractors (no fee):

(1) Maximum size 24 inches x 36 inches, unattached from home. Two (2) signs may be placed on waterfront homes. (One (1) at the road access and one (1) at water access). Golf course lots may also have a second sign at the golf course side of lot. All other improved lots, one (1) sign. All signs must be removed seven (7) days from date of final inspection; the escrow deposit is refunded only after all signs are removed. No subcontractor signs are allowed. Signs not removed within seven (7) days of final inspection will result in a \$25 per day charge to the property owner. All signs not removed within 15 days will be picked up and discarded.

(D) "For Sale by Owner" Signs - See "Realtor & By Owner Signs" under Commercial Signs in § 73.02.

(A&E, Ch. III, § FF1.) (Lake Carroll Association Board approved 9-1989, revised 1-1-1995; Covenants and Restrictions page 5, paragraph I)

### § 73.02 COMMERCIAL SIGNS.

(A) Short Title. The ordinance codified in A&E Rules & Regulations shall be known as the "Commercial Sign Code of Lake Carroll Association" and may be so cited and pleaded and shall be referred to in the A&E Rules & Regulations as the "Commercial Sign Code."

(B) Purpose.

(1) The Commercial Sign code creates the legal framework for signage regulations that is intended to facilitate an easy and agreeable communication between Lake Carroll Association and Commercial Businesses. It recognizes the need to protect the safety and welfare of the public, the need for well maintained and attractive appearance in Lake Carroll Association, the need for adequate business identification and advertising and communication, and the need for promotion of aesthetic values.

(2) An attractive environment maintained by quality control, through adequate maintenance, inspection and by reasonable guidelines formulated to minimize clutter.

(3) This Code authorizes the use of signs visible from public rights-of-way, provided the signs are:

(a) Compatible with their surroundings, pursuant to the objectives of proper design and compatible with zoning regulation:

(b) Allowing and promoting optimum conditions for meeting the sign user's needs while at the same time promoting the amendable environment desired by the general public;

(c) Designed, constructed, and installed and maintained in such a manner that they will not endanger public safety or traffic safety;

(d) Legible, readable and visible in the circumstances in which they are used;

(e) Respectful of the reasonable rights of other advertisers whose messages are displayed.

(C) Required time limit for completion of work. Except or as otherwise provided in the A&E Rules & Regulations it is unlawful for any person to erect, construct, enlarge, move or

convert any sign in Lake Carroll Association, or cause the same to be done, without first obtaining a sign permit for each such sign from the A&E Committee and Building Inspector. These directives shall not be construed to require any permit for cleaning and other normal maintenance or repair of a sign structure for which a permit has previously been issued, so long as the sign or sign structure is not modified in any way. No new permit is required for signs which have permits and which conform with the requirements of the rules & regulations on the date of its adoption unless and until the sign is altered or relocated. If the sign is not fully erected within 90 days, the permit is voidable.

(D) Issuance. Commercial signs on Commercial zoned lots - a one-time fee of \$150 per sign, which requires permit.

(1) The Building Inspector shall issue a permit for the erection, alteration or relocation of a sign within Lake Carroll Association when an application therefore has been properly made and approved and the sign complies with all appropriate rules and regulations of Lake Carroll Association.

(2) The Building Inspector may, in writing, suspend or revoke a permit issued under the provisions of this Chapter whenever the permit is issued on the basis of a misstatement of fact or fraud. When a sign permit is denied by the Building Inspector/A&E Committee, the Building Inspector shall give written notice of the denial to the applicant, together with a brief written statement of the reasons for denial.

(E) Inspection. The person erecting, altering, or relocating a sign shall notify the Building Inspector upon completion of the work for which permits are required.

(1) Inspections. All ground signs shall be subject to a footing inspection and all signs to a final inspection by the Building Inspector. Such inspection will verify proper location and compliance with all approved specifications and conditions of the permit.

(2) Maintenance. Every sign in the Lake Carroll Association, including but not limited to those signs for which no permits or permit fees are required, shall be maintained in good condition at all times. The Building Inspector shall inspect and have the authority to order the painting, repair, alteration or removal of signs which become dilapidated or are abandoned, or which constitute a physical hazard to the public safety.

(F) Permission to install required. No person shall erect, construct or maintain any sign upon any property or building without the written consent of the owner, or their authorized representatives, except as provided in "Association Signs", paragraph (K) below.

(G) Signs of Buildings. No sign on a building shall be larger than four (4) square feet.

(H) Ground Signs.

(1) Number of Ground Signs. One (1) ground sign is permitted for each developed parcel unless provided otherwise in the A&E Rules & Regulations; provided, that no such sign may be closer than 250 feet to any permanent ground sign within Lake Carroll Association on the same side of the street. One (1) additional ground sign may be erected for each additional 500 feet of street frontage in excess of the first 300 feet of street frontage abutting the developed portion of said parcel.

(2) Area of Ground Signs. The maximum area of a ground sign shall not exceed 50 square feet for each face of a double-faced sign or for the sole face of a single-faced ground sign.

(3) The maximum height of any ground sign or sign structure shall be 15 feet.

(4) A ground sign must be set back from the public right-of-way from which it is intended to be viewed the same distance as any setback line required in any residentially zoned property facing the same public right-of-way within 100 feet from the sign.

(5) Where a ground sign projects over a vehicular traffic area, such as driveway or parking lot aisle, the minimum clearance between the bottom of the sign and the ground sign shall be 14 feet.

(I) Realtor and By Owner Signs.

(1) For Sale (on improved lots only):

(a) Maximum 24 x 36 inches, unattached from home. Two (2) signs may be placed on waterfront, golf course, and trail side lots. One (1) at road accesses, one (1) at water access, golf course, and trail side of lot. (Realtor's mailbox must be attached to Realtor's For Sale Sign.)

(b) All other improved lots one (1) sign.

(c) No subcontractor signs are allowed.

(d) All signs must be removed at closing.

(e) No signs allowed on vacant lots.

(2) Open House Signs:

(a) ONE (1) Open House sign may be placed at the nearest main traveled road in addition to sign located at property; multiple open house signs allowed upon approval by Building Inspector and/or A&E Committee.

(b) Sign not to be placed before morning and must be removed by dusk on day of Open House. If signs are not removed, they will be picked up and discarded.

(3) No other remote directional signs are allowed. All such signs will be picked up and discarded.

(J) Ground Signs are to be landscaped around the base, except as outlined "Realtor and By Owner Signs", paragraph (I) above.

(K) Association Signs: The Lake Carroll Association may have logo and identification signs affixed to their buildings. New Association sign applications must be submitted to the A&E Committee for aesthetic and structural approval. Fees are waived on all Association signs.

(L) Prohibited Signs (All signs are subject to A&E approval.)

(1) Generally - The types of signs set forth in this Chapter are expressly prohibited in all of Lake Carroll Association.

(2) Animated and intensely lighted signs - No sign shall be permitted which is animated by means of flashing, scintillating, blinking, or traveling lights or any other means not providing constant illumination.

(3) Changeable copy signs - All manual changeable copy signs and automatic changing signs are prohibited with the exception of public time, temperature and date signs.

(4) Posters and Bills - The tacking, posting or otherwise affixing of signs visible from a public way, located on the walls of buildings, barns, sheds, on trees, poles, posts, fences, or other structures is prohibited unless permitted by A&E Rules and Regulations.

(5) Moving Signs - Except as otherwise provided in A&E Rules and Regulations, no sign or any portion thereof shall be permitted which moves or assumes any motion consisting of a non-stationary or fixed condition except for the rotation of barber poles or permissible changing signs. This section is not meant to prohibit any form of vehicular signage such as a sign attached to a bus or lettered on a motor vehicle.



(6) Parking of advertising vehicles prohibited - No person shall park any vehicle or trailer on a public right-of-way or public property or on private property so as to be visible from a public right-of-way, which has attached thereto or located thereon any sign or advertising device for the basic purpose of providing advertisement of products or directing people to a business or activity located on the same or nearby property or any other premises. This section is not intended to prohibit any form of vehicular signage such as a sign attached to a bus or lettered on a motor vehicle.

(7) Public Areas:

(a) No sign shall be permitted which is placed on any crosswalk, curb, curbstone, sidewalk, post, pole, stake, electrolier, hydrant, bridge, tree, or other surface located on public property or over or across any street or public thoroughfare except as authorized in paragraph (L)(7)(b) below of this section.

(b) Signs shall be allowed in the public areas designated in paragraph (L)(7)(a) above of this section so long as they meet the following requirements:

1. Non-illuminated, single- or double-faced ground sign.
2. Not exceeding the height of 36 inches above the top of the curb.
3. Not exceed six (6) square feet in area.
4. Only allowed on Sundays between the hours of 12 to 6 p.m.
5. No Lake Carroll Association sign permit will be required for a sign under this section.

(c) Any sign located on public property in violation of this section may be removed by Lake Carroll Association. The person responsible for any such illegal sign shall be liable for the costs incurred in the removal thereof and Lake Carroll Association is authorized to affect the collection of said cost. The remedy is not exclusive. Lake Carroll Association reserves the right to prosecute violators as set forth in A&E Rules and Regulations.

(8) Banners - Banners, pennants, searchlights, balloons, or other gas-filled figures may be used as follows:

- (a) Signs described above are not allowed except as noted below.
- (b) Signs described above may be displayed at the opening of a new business in the business, or office and research district for a single period not the exceed 15 days.
- (c) In business, office and research districts, gas or air-filled figures in excess of 27 cubic feet or which have a cross-sectional dimension greater than three (3) feet are expressly prohibited. Balloons may be utilized but not aggregated or grouped together in excess of 27 cubic feet and in no event shall have a cross-sectional dimension greater than three (3) feet.
- (d) Permits are required for signs listed in sections above.

(9) Flags - Flags other than those of any nation, state or political subdivision or corporate flag are prohibited.

(10) Swinging Signs - Swinging signs are prohibited.

(11) "A" Frame Signs - All A-frame or sandwich board, sidewalk or curb signs are prohibited.

(12) Portable Signs - Portable or wheeled signs are prohibited. This shall not be interpreted to prohibit lettering on motor vehicles or permissible advertising on buses.

(13) Roof Signs - All roof signs are prohibited.

(14) Visible Frames - Visible angle iron frames or structures to support projecting signs are prohibited.

(15) Flashing Lights - Flashing lights or flashing signs located inside a premises are expressly prohibited if visible from a right-of-way. Exception, holiday lights that flash on and off.

(16) Unclassified Signs - The following signs are also prohibited, which:

- (a) Bear or contain statements, words or pictures of an obscene, pornographic, immoral character, or which contain advertising matter which is untruthful;
- (b) Are painted or attached to any fence or any wall which is not structurally a part of a building, except to identify a residence or residence structure by means of posting the name of the occupant or structure, and the street address;
- (c) Operate or employ any stereopticon or motion picture projection or media in conjunction with any advertisements or have visible moving parts or any portion of which moves, or gives the illusion of motion except as permitted in A&E Rules and Regulations;
- (d) Emit audible sound, odor or visible matter;
- (e) Signs for advertising which purport to be, or are an imitation of, or resemble an official traffic sign or signal, or which bear the words "Stop," "Go Slow," "Caution," "Danger," "Warning," or similar words;
- (f) Signs which by reason of their size, location, movement, content, coloring or manner of illumination may be confused with or construed as a traffic control sign, signal or device, or a warning sign, or the light of an emergency or road equipment vehicle, or which hide from view any traffic or street sign or signal or device.

(A&E, Ch. III, § FF1.) (Lake Carroll Association Board approved 9-1989, revised 1-1-1995; Covenants and Restrictions page 5, paragraph I; LCA Board approved 8-25-2009 General Provisions)

### **§ 73.03 POLITICAL CAMPAIGN SIGNS.**

- A. No signs of any type are allowed to be placed, by anyone other than the Lake Carroll Association, within any Common Area or Reserved Area.
- B. No signs of any type are allowed to be placed on any lot upon which a house has not been constructed.
- C. Campaign signs may only be placed on the owner's private property.
- D. All campaign signs shall be no larger than 2 feet by 3 feet (or 6 square feet). All signs shall be made of a bio-degradable material. No sign shall have any blinking lights, mimic traffic signals or could cause confusion for motorists.
- E. Signs placed on the owner's private property shall be limited to one sign for a candidate for each office. Signs shall not be posted closer than 20 feet from the property line closest to the roadway. No sign shall be placed in a manner that obstructs the view of motorists, pedestrians and cyclists.
- F. If a campaign sign is posted anywhere but on the owner's private property, the Lake Carroll Association shall be allowed to remove and dispose of all such signs.
- G. Campaign signs shall not be allowed to be posted more than 45 days prior to the election and must be removed no more than 7 days following the election.

## **CHAPTER 74: A&E COMMITTEE POLICIES**

Section

74.01	Violation
74.02	Retaining walls, waterfront decks, piers, etc.
74.03	Driveways and culverts
74.04	Adjacent property
74.05	Construction hours and debris removal
74.06	Maintenance of lots
74.07	Applying of fertilizers in Lake Carroll
74.08	Mowing policy
74.09	Nuisance animal control policy

### **§ 74.01 VIOLATION.**

**(Any violations within this section will result in fines as outlined in Fine Structure - See § 70.16.)**

(A&E, Ch. IV)

### **§ 74.02 RETAINING WALLS, WATERFRONT DECKS, PIERS, ETC.**

A minimum sideline set back of 15 feet is required without the adjacent property owner's agreement in Sections 15, 19, 21, 22, 23, 24, 25, 26, 27, 28, 29, 31. The A&E Committee must also approve variances.

(A&E, Ch. IV, § A)

### **§ 74.03 DRIVEWAYS AND CULVERTS.**

(A) Refer to "Building Requirements" CULVERT REQUIREMENTS AND DRIVEWAYS, § 72.21.

(B) In sections 15, 19, 21, 22, 23, 24, 25, 26, 27, 28 and 31 driveways may not be installed closer than 15 feet to the adjacent property line without first obtaining a signed adjacent property owner agreement form and/or a variance granted by the A&E Committee. Minimum with signed adjacent property owner agreement form is five (5) feet. In sections 1, 2, 3, 4, 5, 12, 13, 16, 17, 18, 20 and 30 driveways may not be installed closer than five (5) feet to the adjacent property line without a signed adjacent property owner agreement and/or a variance granted by A&E Committee.

(A&E, Ch. IV, § B)

### **§ 74.04 ADJACENT PROPERTY.**

All property owners or contractor of record must obtain written permission to use property other than the building site for access to construction site or any other purpose. This permission must be obtained prior to such use and filed with the A&E Committee. Violation of this policy will result in the issuance of a citation. A "stop order" will be placed on the job of

record along with fines. All fines shall be paid before the job of record will be allowed to proceed.

(A&E, Ch. IV, § C)

**§ 74.05 CONSTRUCTION HOURS AND DEBRIS REMOVAL.**

(A) Due to noise abatement, construction hours shall be as follows:

6:30 am to 6:30 pm	Truck Delivery
7 a.m. to 7 p.m.	Monday through Friday
7 a.m. to 6 p.m.	Saturday
10 a.m. to 6 p.m.	Sunday

(B) During months of high temperature (80+degrees), shingling contractors may begin at 6 a.m.

(C) DEBRIS REMOVAL: Effective January 15, 1997 all construction sites shall be required to have a dumpster in place at beginning of framing through dry walling of project. This Dumpster must be unloaded when capacity is reached. NO debris will be allowed to be thrown on ground or allowed to blow in ditches or other property. A fine of \$250.00 will be assessed and a stop order placed on job of record until fine is paid and problem is corrected. After dumpster is removed, all debris is to be kept in the garage or removed from site.

(D) Effective January 1, 1998 no construction burning shall be allowed. Any contractor found burning shall be fined \$250.00 for the offense and a stop order issued until the fine is paid.

(A&E, Ch. IV, § E)

**§ 74.06 MAINTENANCE OF LOTS.**

(A) Refer to Article III, Section D of Covenants and Restrictions.

(B) Lake Carroll POA Lot maintenance/mowing rules are in part designed to conform to the state of Illinois statutes.

(C) Illinois Noxious Weed Law: Article I.

(1) Rule 1.01. It shall be the duty of every person to control the spread of and eradicate all noxious weeds on lands owned or controlled by him or her in the State of Illinois.

(2) Rule 1.03. It shall be the duty of each control authority to carry out its duties and responsibilities as set forth in the act and these rules and regulations.

(D) Noxious weeds: Marijuana, ragweed, Canada thistle, perennial sow thistle, musk or nodding thistle, perennial members of the sorghum family including Johnson grass, sorghum alum and other Johnson grass/sorghum crosses with rhizomes.

(A&E, Ch. IV, § F)

**§ 74.07 APPLYING OF FERTILIZERS IN LAKE CARROLL.**

(A) CONTRACTORS:

(1) Any landscaper who sprays or professional sprayer of chemicals on land within Lake Carroll needs to have a State of Illinois Spray License and must submit a copy of that license to Lake Carroll when he or she registers each year. A “no-charge” permit request

must be submitted to A&E and approved before any or all spraying by Contractors. The permit must name products (MSDS Sheet) being used. **The application of Phosphorous is not permitted in any form in Lake Carroll** as stated per Illinois state codes, except when starting new lawns. Though the spreading of some dry chemicals does require a license, a “no-charge” permit request must be filed for all and approved before any application is put down in Lake Carroll. These products must also be named (MSDS).

(2) **Failure to adhere to this regulation will cause an immediate “stop-work” order and a \$250 fine.**

(B) MEMBERS: Members must not apply any Phosphorous of any kind within Lake Carroll.

(A&E, Ch. IV, § G)

### § 74.08 MOWING POLICY.

(A) *Lot Mowing Unimproved Lots:*

(1) Lot to be mowed entirely to gain control of weeds. If a member is cutting their own lot, they must notify the LCA Office at 815-493-2552, [by 12:00 pm the day following the end of the mowing period. Provide your name, section and lot, and date mowed].

(2) Mowing dates are:

(a) First Mowing - No earlier than first Saturday in May and no later than third Sunday in June based on management’s decision and vegetation growth. Typically, first Saturday in May.

(b) Second Mowing - No earlier than first Saturday in August and no later than first Saturday in September based on Management’s decision and growth of vegetation. Typically, first Saturday in August.

(3) *Fee Schedule:*

(a) The Association maintenance staff, or its agents will mow the lot in question where the property owner is found to be in noncompliance with this policy. The property owner of record will be assessed a mowing fee (including penalty) as established in the approved fee schedule.

(b) This fee is per mowing. Please note that there are two (2) mowing periods per year. All mowing fees will be subject to collection as are other Association dues, assessments, and fees. Failure to pay this fee within 30 days from billing date will result in additional late charges as established in approved fee schedule. All mowing fees must be paid in full to consider a member in good standing.

(c) Mowing Fees for lots under a contiguous lot agreement or re-platted lots will be charged by the originally platted lot but in no case will owner be charged more than the fee for “a lot in excess of one (1) acre.”

(A&E, Ch. IV, § H)

(B) *Mandatory Mowing Improved Lots:*

(1) *Improved Lot:* Any lot, which has a home erected, must have the lawn planted and maintained three (3) months after occupancy or final inspection. One thousand dollars will be held in escrow until in compliance, exceptions during winter months when ground is frozen. Mandatory mowing must begin after the occupancy or final inspection has been issued.

(2) All improved lots must be kept in a neat and orderly fashion. Lawn must not be allowed to grow taller than six (6) inches in height. The Association will give the owner a

two (2) week notice to comply for any lots in violation of this height restriction. Failure to maintain will result in a fine as established in the approved fee schedule. The Association will arrange for mowing and mowing fees would be added to the fine if schedule is not met. **All lots must be mowed entirely to gain control of weed problems.**

(C) *Exceptions to this Policy:*

(1) Those lots designated as being fully wooded, as outlined in census taken by the Building Inspector.

(2) All improved lots larger than one (1) acre may plant some small areas (not to exceed 1,000 square feet total) in wildflowers. However, area must be kept free of noxious weeds and balance of lot must be fully mowed. All lots must be kept in a neat and orderly fashion.

(3) Areas set-aside by the Association as natural prairie.

### **§ 74.09 NUISANCE ANIMAL CONTROL POLICY.**

(A) Trapping in Lake Carroll is under the supervision of the General Manager, Lake Manager, and A&E Building Inspector.

(B) Trappers trapping for Lake Carroll Association on Common Areas and Reserved Areas is for the control of animals that impede the lake, ponds, and dam structures. Trappers are required to register with the A&E Building Inspector prior to trapping commencement. To register, you must:

(1) Complete a Contractor's Registration Card (\$50 fee), available from the A&E Office.

(2) Provide copy of your IDNR Nuisance License.

(3) Provide proof of five hundred thousand (\$500,000) liability insurance.

(A&E, Ch. IV, § I)

**APPENDIX A: LAKE CARROLL ASSOCIATION COVENANTS AND RESTRICTIONS SECTIONS 1, 2, 3, 4, 5, 12, 13, 16, 17, 18, 20, 30**

- I. SINGLE FAMILY RESIDENTIAL.
  - 1. Required Area of Building.
    - a. 1. A-Lots 1,000 square feet, at least 75% must be contained on First Floor.
    - 2. No portion of required area to be below ground level.
    - b. 1. B-Lots 800 square feet: at least 800 Square feet must be contained on First Floor.
    - 2. No portion of required area to be below ground level.
- II. SETBACKS: FROM ORIGINAL LOT LINES, NOT QUIT CLAIM LOT LINES.
  - 1. Thirty (30) feet from front lot line.
  - 2. Ten (10) feet from side lot lines.
  - 3. Rear Lot Lines:
    - a. Twenty-five (25) feet or 25 percent (25%) depth of lot, whichever greater. However, lakefront lots at least 746 pool level.
    - b. Section 13: Fifty (50) feet (Applies to lake lots only).
    - c. Section 12, 16 and 30: Thirty-five (35) feet (Applies to lake lots only).
- III. IMPERVIOUS SURFACES NOT TO EXCEED **40 percent (40%) OF PROPERTY AREA.**
- IV. No tree over three (3) inches in diameter may be removed from any lot without consent of the A&E Committee.
- V. No tree shall be planted without the consent of the A&E Committee.

**NOTE:** Maps are located in the office indicating whether your lot is an A or B lot.

All setbacks refer to structures. Any above grade structures on waterfront properties are to follow the 15 ft. setback rule. Septic seepage fields are not considered structures. Septic seepage fields shall not be installed closer than 25 ft. (twenty-five feet) from the platted ownership line on the lake side of the lot, and in no case may they be run in utility easements.

Definition of a **STRUCTURE** - Any form, building, tower, LP tank and enclosure constructed or placed above the land is considered a structure.

Irrigation systems are allowed within confines of lot lines.

**APPENDIX B: LAKE CARROLL ASSOCIATION COVENANTS AND RESTRICTIONS SECTIONS 15, 19, 21, 22, 23, 24, 25, 26, 27, 28, 29, 31**

- I. SINGLE FAMILY RESIDENTIAL.
  - 1. Minimum Area.
    - a. Waterfront lots: 1,500 square feet with a minimum of 800 square feet of living space on ground level. No portion of minimum being below ground level.

b. Other lots: 1,000 square feet with a minimum of 800 square feet of living space being on ground level. No portion of minimum being below ground level. (Raised ranches exception).

II. SETBACKS: FROM ORIGINAL LOT LINES NOT QUIT CLAIM LOT LINES.

1. Thirty (30) feet from front lot line.
2. Twenty-five (25) feet from side lot lines.
3. Fifty (50) feet from rear lot line. However, lakefront lots at least 746-pool

level.

III. IMPERVIOUS SURFACES NOT TO EXCEED 40% OF PROPERTY AREA.

IV. No tree over six (6) inches in diameter may be removed from any lot without written consent of the A&E Committee.

V. No tree shall be planted without the consent of the A&E Committee.

All setbacks refer to structures. Any above grade structures on waterfront properties are to follow the 15 ft. lake frontage setback rule. Septic seepage fields are not considered structures. Septic seepage fields shall not be installed closer than 25 ft. (twenty-five feet) from the platted ownership line on the lake side of the lot, and in no case may they be run in utility easements.

Definition of a **STRUCTURE** - Any form, building, tower, LP tank and enclosure constructed or placed above the land is considered a structure.

Irrigation systems are allowed within confines of lot lines.

## APPENDIX C: LAKE ACCESS LOTS; RANCHETTE AND EQUESTRIAN LOTS

### LAKE ACCESS LOTS

(A) The following are considered to be lake access “finger” lots. These lots may be considered for reduced square footage to a minimum of 1,200 square feet. The house may not be in the narrow portion (stem) of the said lot. *No variances will be granted.*

Section	Lot(s)
21	51
23	34, 39, 42
24	13, 17, 27, 50, 51, 57, 58, 63, 70, 81, 83, 86, 89, 94
25	51, 57, 58, 59, 60, 61, 67, 75, 83
26	11, 29, 57, 60, 64
27	40
28	28, 51
<b><i>The above lots were approved for reduced square footage May 6, 1989.</i></b>	

(B) Lake access lots may request a variance for sideline setbacks for piers and decks. Committee may grant variances to within ten (10) feet of side lot line. This will require an adjacent property owner consent form signed by the adjacent property owner or property owners. The adjacent property owner shall have 30 days to either agree or object to variance. After 30 days, with no adjacent lot response, the A&E Committee may act on the variance.



## **RANCHETTE and EQUESTRIAN LOTS**

(A) General Rules:

(1) (a) Setbacks for dwellings in applicable lots shall conform to those in the Covenants & Restrictions for lots and sections, namely:

1. Thirty (30) feet from front lot line.
2. Fifty (50) feet from the rear lot line.
3. Twenty-five (25) feet from side-lot lines.

(b) Such setback shall be eligible for a variance if satisfactory evidence of unreasonable deprivation of use of by the owner is furnished and appropriate “adjacent owner’s” consent is obtained and furnished to the A&E Committee.

(2) No stable or other accessory building shall be constructed on a lot until a residence is constructed on such lot.

(3) Location of a septic system, etc. shall conform to other mandatory building regulations of the Association.

(4) Construction of structures shall conform to normal Lake Carroll building regulations unless specifically mentioned in the following specific requirements.

(B) Specific requirements:

(1) Due to the size of the lots affected, the setback requirements for Auxiliary Buildings (barns, stables, loafing sheds etc.) shall be behind the rear line of the residence.

(2) Fencing:

(a) Shall be constructed no less than ten (10) feet from ALL lot lines for proper separation from neighboring equestrian or Ranchette lots and provide for utility maintenance requirements.

(b) Allowed fencing shall be limited to:

1. Color shall be compatible with surrounding buildings and not disruptive to the neighborhood.

2. Type, formatting, and style must conform to good neighborhood appearance while providing size protection to inhibit horse egress and other animal ingress to the affected properties.

3. Dog runs - See “Fences, General” in § 72.36.

(3) Accessory Buildings:

(a) Color shall conform and be compatible to that of the dwelling on the lot.

(b) No accessory buildings shall be erected prior to construction of a dwelling on the property. No such structures shall ever be used for human occupancy or habitation.

(c) No more than three (3) accessory buildings shall be allowed without the A&E Committee’s permission on Equestrian or Ranchette lots:

1. One (1) “Barn” or “Horse Stable” conforming to size requirements for maximum number of horses permitted for the lot(s) involved in the applicable ownership interest.

2. One (1) “Loafing shed” or similar three (3) sided structure for horse shelter and/or hay/feed storage.

3. One (1) Accessory out building for residential purposes for equipment or a garage.

Lake Carroll Association, IL Code of Ordinances

4. Variance to sizes and construction of the above accessory structures, foundations, etc. may be allowed in individual cases based on review of structure and plot plans submitted, lot characteristics and animal population of the property.

5. Stable and horse exercise area distance from a residential well shall conform to State of Illinois Health Department requirements, currently 75 feet.

6. Structure building rules shall conform to standard Building Regulations published by the Lake Carroll Association.

a. Pole buildings will be permissible provided they meet color and compatibility requirements with main residence on the property.

b. Dirt floors (vs. concrete pads) are permissible in horse barns and loafing sheds.

(4) Miscellaneous regulations:

(a) Where construction of a structure on the lots (including dwelling, accessory or horse shelters or fencing) involves more than one (1) lot, a replat of affected lots to one (1) is mandatory and a copy of resurveyed replat must be included in the presentation package to the A&E Committee.

(b) While not mandatory, it is strongly recommended that fire detection alarms be placed in horse barns or shelters.

(c) The residential septic shall not be located under horse exercise or pasture areas nor under accessory structures. Rules on access to or driving over septic fields shall conform to standard Building Regulations for Lake Carroll.

(d) In accordance with "Nuisance" and Animal rules in the Covenants & Restrictions, horses shall be properly maintained within the lot(s) and related garbage and animal waste shall be managed and disposed of so as not to constitute unsightly, unsanitary or health hazards.

**APPENDIX D: LAKE CARROLL ASSOCIATION FORMS**

- A. Alarm Information (2 pages)
- B. Building Permit Application Form (6 pages)
- C. Contractor & Sub-Contractor Registration Card (4 pages)
- D. Outdoor Lighting (1 page)
- E. Mailbox Placement and Roadway Posting (1 page)
- F. Replat Application Form (1 page)
- G. Septic Pumping/Inspection Form
- H. Surveyor List
- I. Vacate Previous Replat Form (1 page)
- J. When Using Contractor (1 page)

FIND A&E BUILDING FORMS AND DOCUMENTS FOR THE LIST  
ABOVE ON THE LAKE CARROLL WEBSITE

[www.golakecarroll.com](http://www.golakecarroll.com).

Look under CONTACT > [Contractor Resources](#).

**AMENDMENTS**

<b><i>Lake Carroll Association Board approved 9-1989</i></b>		
<b><i>Section</i></b>	<b><i>Description</i></b>	
73.01	Non-commercial signs	
73.02	Commercial signs	
<b><i>Lake Carroll Association Board approved 1-1-1992</i></b>		
<b><i>Section</i></b>	<b><i>Description</i></b>	
72.45	Fuel storage	
<b><i>Lake Carroll Association Board Approved 4-23-1993</i></b>		
<b><i>Section</i></b>	<b><i>Description</i></b>	
72.29	Residential piers, docks and swim platforms	
<b><i>Revised 1-1-1995</i></b>		
<b><i>Section</i></b>	<b><i>Description</i></b>	
73.01	Non-commercial signs	
73.02	Commercial signs	
<b><i>1-11-1997</i></b>		
<b><i>Section</i></b>	<b><i>Description</i></b>	
72.18	Shoreline stabilization policy	
<b><i>POA Board approved 8-1-1997</i></b>		
<b><i>Section</i></b>	<b><i>Description</i></b>	
72.18	Private sewage disposal system	
<b><i>1-11-2002, M02.01.02</i></b>		
<b><i>Section</i></b>	<b><i>Description</i></b>	
72.31	Gazebos	
<b><i>4-23-2005, M05.04.13</i></b>		
<b><i>Section</i></b>	<b><i>Description</i></b>	
72.30 et. seq.	Accessory buildings (including, but not limited to sheds, beach houses)	
<b><i>7-1-2007</i></b>		
<b><i>Section</i></b>	<b><i>Description</i></b>	
72.36(B)	Fences	
<b><i>1-2008, M01.09.7/M01.10.4; repeat of "GG" of A&amp;E Rules &amp; Regulations</i></b>		
<b><i>Section</i></b>	<b><i>Description</i></b>	
72.05	Platting/replatting of lots	
<b><i>BOD approved 12-22-2008</i></b>		
<b><i>Section</i></b>	<b><i>Description</i></b>	
70.16	Fines	
<b><i>LCA Board approved 8-25-2009</i></b>		

Lake Carroll Association, IL Code of Ordinances

<i>Section</i>	<i>Description</i>	
73.02	Commercial signs; General Provisions	
<b><i>Revised and approved 1-22-2010</i></b>		
<i>Section</i>	<i>Description</i>	
72.27	Electrical requirements	
<b><i>Major changes BOD Approved 11-18-2011</i></b>		
<i>Section</i>	<i>Description</i>	
72.15	Campground	
<b><i>Major changes BOD Approved 11-18-2011; Effective 1-1-2013</i></b>		
<i>Section</i>	<i>Description</i>	
72.15	Campground	Campground
70.15, 70.16	Fine structure policy and fines	Fine structure policy and fines
Appendix D	Required inspection schedule	3. Foundation insulation inspection prior to backfill
Appendix D	Required inspection schedule	7. Insulation inspection prior to drywall being installed
<b><i>Major changes BOD Approved 10-18-2013; Effective 1-1-2014</i></b>		
<i>Section</i>	<i>Description</i>	
70.02	Conservation code	2013 Illinois Energy Conservation Code
72.15	Campground/building plans	Accessory buildings/species and grade of lumber requirements
70.15	Fine structure policy and fines	Fine structure policy and fines
Appendix D	Mandatory inspection schedule	Revised inspection schedule
Appendix D	Insurance requirements	
BOD Apv 11-4-2013	Registered contractors list	Now only available at <a href="http://www.golakecarroll.com">www.golakecarroll.com</a> or at the Admin Office
<b><i>Major changes BOD Approved 10-24-2014; Effective 1-1-2015</i></b>		
<i>Section</i>	<i>Description</i>	
70.02	Code Revisions	2012 International Building Code
70.02	Code Revisions	2012 IL Energy Conservation Code
70.02	Code Revisions	2004 IL Plumbing Code
70.02	Code Revisions	2012 International Residential Code
70.02	Code Revisions	1997 IL Accessibility Code
71.01, 71.15— 71.32, 71.45, 71.46, 71.60— 71.65	Rule Revisions	Plan Requirements
<b><i>Changes made as part of 2016 update</i></b>		

Lake Carroll Association, IL Code of Ordinances

<b>Section</b>	<b>Description</b>	
70.02	Code Revisions	
70.15	Fine structure policy revised	
70.16	Fees and penalties amended	
Chapter 71	Amended to add "Lake Carroll" to title	
71.16	Divisions (A), (B)(3) and (C)(2) amended	
71.17	Division (I) amended	
71.18	Division (A) amended	
71.24	Title amended to add a "-"	
71.27	Divisions (A) and (Q) amended	
71.28	Division (A) amended	
71.31	Guardrails/handrails amended	
71.33	Divisions (A) and (B) amended	
71.61	Divisions (E) and (F) amended	
Chapter 72	Amended to add "Lake Carroll" to title	
72.01	Building approval moved here from 72.21	
72.01 - 72.04	Sections renumbered	
72.04	Adjacent property amended	
72.15	Campground amended	
72.16	Lot plot plans amended	
72.17	For permit issuance and completion of construction amended	
72.20	Division (A) amended	
72.21	Building approval moved to 72.01 Renumbered 72.21 amended	
72.22 - 72.44	Sections renumbered	
72.23	Miscellaneous building requirements amended	
72.24	Erosion control amended	
72.30	Sheds; title change and section amended	
72.31	Gazebos; Divisions (A)(7) and (B)(4) added	
72.32	Barns, stables and loafing sheds added	
72.33	Beach houses added	

Lake Carroll Association, IL Code of Ordinances

72.34	Detached garages added	
72.42	Landscaping amended by addition of divisions (E) through (H)	
Variance Policy	Intro paragraph added prior to 72.55	
72.55	Variations generally amended	
72.57	Notices; division (C) amended	
72.58	Variance criteria added	
72.58	Variance criteria section added	
73.02	Commercial signs; division (B)(2) amended	
74.03	Divisions (A) and (B) amended	
74.05	Erosion control deleted	
74.06 - 74.10	Sections renumbered	
74.08	Mowing policy; division (B)(2) amended	
Appendix A	Division III. 1. deleted	
Appendix B	Division III. 1. deleted	
Appendix D	“When Using a Contractor” information added	
Appendix D	Contractors List; table amended	
<b><i>Changes made as part of 2017 update</i></b>		
<b><i>Section</i></b>	<b><i>Description</i></b>	
70.02	2011 NEC (Electrical Code) added	
70.15	Fixed spacing issues in divisions (A)(1) and (A)(5)	
70.16	Fines and penalties amended	
71.66	Tear-down guidelines section added	
72.05	Platting/replatting of lots; entire section replaced	
72.27	Electrical requirements; amended section	
72.34	Detached garages; amended division (F)	
74.08	Mowing fee amended in division (D)(1)	
Appendix B IV	Waterfront vertical structure amended	
Appendix D	Revised and replaced images	
<b><i>Changes made as part of 2018 update for 2019</i></b>		
<b><i>Section</i></b>	<b><i>Description</i></b>	
70.15	Added division (17)	
71.15	Revised division (A)(1)	
71.17	Revised division (A)	
71.29	Revised division (A)(2)	

Lake Carroll Association, IL Code of Ordinances

72.05	Revised division (A)(8)(c)
72.28	Added paragraphs (a), (b) and (c) to division (B)(1), revised division (D)(3)
72.30	Revised divisions (D), (G) and (I)
72.31	Revised divisions (A)(1) and (7) and (B)(4)
72.32	Revised divisions (C) and (F)
72.35	Deleted division (I)
72.55	Revised section
73.01	Added paragraph (1) to division (B)
Appendix A IV	Added note
Appendix B IV	Revised note
Appendix D	Revised “When Using a Contractor” form and surveyors in “Contractors List” form
<b><i>Changes made as part of 2019 update for 2020</i></b>	
<b><i>Section</i></b>	<b><i>Description</i></b>
71.15	(C)(3) New home plans submission requirements
71.66	(H) Formatting correction
72.05	(A)(10)(b) Delete
72.25	(A) Clarifying unit of measure – ¾ inch
72.30	(H) Delete (741 foot line)
72.31	(A)(6) Delete (741 foot line)
72.31	(B)(3) Delete (741 foot line)
72.31	(B)(4) Clarifying no toilets
72.33	(H) Delete (741 foot line)
72.35	(H) Wooden support post(s) cannot be below grade or embedded in foundation
72.47	New (A)(B) Regarding temporary structures
74.08	(A)(3) Reference current fee schedule for unimproved lot mowing fees
74.08	(A)(3)(b) Reference current fee schedule for late fees
74.08	(B)(2) Reference current fee schedule for improved lot mowing fees
Appendix A	New V. Must have A&E permission to plan any tree
Appendix B	New V. Must have A&E permission to plan any tree
<b><i>Changes made as part of 2020 update for 2021</i></b>	
<b><i>Section</i></b>	<b><i>Description</i></b>
71.16	(B)(2)NEW(a) Submit PDFs for structures with condition space.
71.31	Change handrail height from 30 to 36, to 34 to 38 from 2015 IRC (R311.7.8.1)
72.00	Chapter 72 Chapter headings: 72.31 Gazebos/Pergolas/Pavilions and 72.39 Satellite Dish
72.00	General Provisions – (A), (A)(1) and Note
72.20	Revised sub-chapter heading: adding Septic
72.29.1	New heading: Lake Structures, Debris, and Buoys



Lake Carroll Association, IL Code of Ordinances

72.31	Revised sub-chapter heading: adding Pergolas/Pavilions
72.39	Revised sub-chapter heading: adding Dish
72.20	(B) Change letters to reminders
72.29.1	New Lake Structures, Debris, and Buoys
72.30	(C) Reorganize outline format
72.30	New (C) (3) Maximum Height Structure
72.30	New (I), (J), & (K) – Additional shed requirements
72.31	Heading correction – added Pavilions
72.31	New Size restrictions: (A)(1)(a), (b), & (c)
72.31	New (B)(1)(c) & (2)(c) Maximum height 20ft for Gazebo/Pergola/Pavilion
72.32	(D) Barns, etc. maximum structure height 20ft
72.33	(A) Same as new construction
72.33	(C) SqFt and impervious details added
72.33	(D) Maximum sidewall and overall height
72.33	(F) Colors to be indicated on plans
72.33	(G) Plumbing designed by licensed professional and on drawings
72.33	(H) Deleted “741 foot line” from rule
72.33	New (J), (K), (L), & (M)
72.34	(C) Survey to show garage, setbacks, well & septic, and impervious surface calculation
72.34	(E) Colors to be indicated on plans
72.34	NEW (G), (H), (I), & (J)
72.35	Section clarification to “Attached Decks”
72.35	Addition to reference to DCA-6
72.35	(A) Colors to be indicated on plans
72.35	(B), (C), & (D) Deleted “detached”
72.35	(E) Stair handrail required
72.35	(G) Footings and piers follow DCA-6
72.35	New (I), (J), & (K)
72.38	Section heading changed to include “AND FLAGPOLES”
72.38	New (F) Survey showing location, setbacks, and lot lines
72.39	(C) 36” or less satellite dish on under a 12ft pole/post not attached to house, no permit
72.41	(G)(2) Indicate pool dimensions & structures and minimum of 746’ elevation
72.41	New (I) New (I) re Electrical Plans
72.42	(A) Mature tree driplines must be within property lines
72.42	(G) Removed “two (2) feet or higher” from rule
72.42	New (H) Landscaping
72.45	(A) Removed “Residential or” from rule

Lake Carroll Association, IL Code of Ordinances

72.45	New (B) Prohibited fuel sources on residential property
72.46	(4) Deleted roof loading max pounds/sqft. New(4): A State of Illinois licensed architect or structural engineer required to confirm adequate roof support.